

# DUAL Z Direct

Dual Channel Passive Direct Box

Artcessories



## User's Manual



## IMPORTANT SAFETY INSTRUCTION – READ FIRST



This symbol, whenever it appears, alerts you to the presence of uninsulated dangerous voltage inside enclosure-voltage that may be sufficient to constitute risk of shock.



This symbol, whenever it appears, alerts you to important operating and maintenance instructions in the accompanying literature. Please read the manual.

**Read Instructions:** Retain safety and operating instructions for future reference. Heed all warnings printed here and on the equipment. Follow the operating instructions printed in this user guide.

**Do not open:** There are no user serviceable parts inside. Refer any service work to qualified technical personnel only.

**Grounding:** Only connect the unit to equipment with properly grounded mains power. Do not defeat the grounding and polarization means of the power cord plug of the connected equipment. Do not remove or tamper with the ground connection on the power cord of the connected equipment.

**Environment:** Protect from excessive dirt, dust, heat, and vibration when operating and storing. Avoid tobacco ash, drink spillage and smoke, especially that associated with smoke machines.

**Handling:** Protect the controls from damage during transit. Use adequate padding if you need to ship the unit. To avoid injury to yourself or damage to the equipment, take care when lifting, moving or carrying the unit.

**Servicing:** Refer servicing to qualified technical personnel.

**Installation:** Install the unit in accordance with the instructions printed in the user guide.

## **INTRODUCTION:**

Thanks for purchasing Applied Research and Technology's DUALZDirect. The DUALZDirect provides two independent high quality totally passive interfaces that let you connect instrument, line, or speaker level signals to a mixer or other balanced inputs through high performance audio isolation transformers. Each of the high impedance single-ended 1/4" inputs is converted by a transformer into an isolated, balanced, low impedance signal output. The DUALZDirect's audio transformers have an extremely flat and wide frequency response and can handle high signal levels. This gives the DUALZDirect a very clean and neutral sound with a wide variety of signal sources and over long signal runs in high noise environments.

The input ATTENUATOR switches allow for a wide range of signal levels and the input THRU jacks allows for tapping off of your signal chain. The GROUND LIFT switches let you totally separate the input and output signal grounds, when appropriate, to isolate two systems, thereby reducing hum and ground-loop noise.

What further sets the DUALZDirect apart from other "DI" boxes are its extended features and versatility. We have added switchable low pass FILTERs that cut out all very high frequency interference. These Bessel filters on the outputs are placed out of the audio range and are

primarily intended to reduce radio frequency interference before it gets into the main system. The filters are also very effective in reducing any digital computer noise artifacts when using the DUALZDirect as an interface between a computer-based audio workstation and your monitors. The PHASE INVERT switches, while not normally included with your "run of the mill" DI box, have been added to allow you to switch signal polarity right at the source. This feature is especially handy when you are combining a direct tap with a microphone feed in the mix.

The compact black-anodized all aluminum case and it's passive design allow the DUALZDirect to provide years of trouble free service in Live Sound, Permanent/Fixed Install, D.J., and virtually any PA application. It's full feature set, rugged construction, and high-end specifications make the DUALZDirect the obvious choice.

## **FEATURES:**

- Fully passive, high performance transformer design. No battery required.
- Converts 50k Ohm inputs into 600 Ohm balanced outputs
- Switchable input attenuation (0, -20, -40 dB)  
Switchable low pass filter

- Switchable phase invert
- Switchable ground lift (fully isolates inputs from chassis and outputs)
- XLR connectors for balanced outputs
- Rugged extruded aluminum case

## **INSTALLATION and OPERATION:**

1. Connect your instrument, line, or speaker level signal to either of the **INPUT 1** or **2** 1/4" TRS phone jacks. Connect one end of a phone jack cable to the corresponding **THRU** 1/4" TRS phone jack and the other end to where your signal was going to, if connecting the DUALZDirect inline in the signal path. Repeat for the other **INPUT** and **THRU** jacks if desired.

2. Connect a balanced line cable between the corresponding **OUTPUT 1** or **2** male XLR connector on the rear panel and the balanced inputs of your audio gear. Repeat for the other **OUTPUT** if desired.

3. Set the input **ATTENUATOR** switches for best signal strength and clarity. Select the **FILTER** if desired (it won't affect normal audio frequencies). Select the **GROUND LIFT** feature to lower hum and other ground loop noise, if present. The **PHASE INVERT** feature may be used to correct phase error problems elsewhere in the audio system.

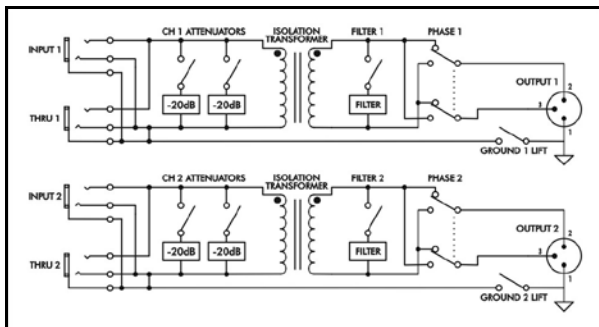

**Signal Flow Chart**

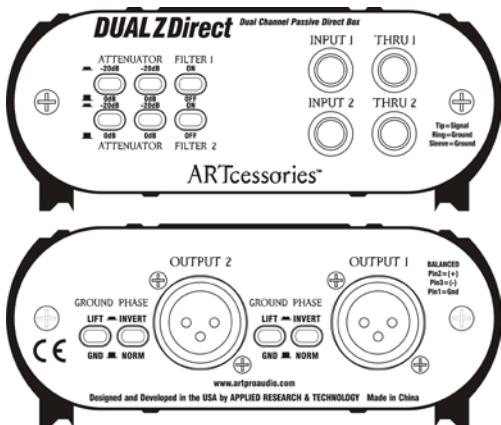



## **SPECIFICATIONS:**

<b>Frequency Response:</b>	10 Hz - 50 kHz, $\pm 0.5$ dB @ +4 dBu
<b>THD:</b>	.01% typical @ 1 kHz, +18 dBu <.05% @ 100 Hz, +18 dBu
<b>Channel Separation:</b>	> 80 dB (typical)
<b>Input Connections:</b>	1/4" TRS unbalanced (2), 50k Ohm
<b>Thru Connections:</b>	1/4" TRS (2)
<b>Output Connections:</b>	XLR male balanced (2), 600 Ohm
<b>Input Attenuation:</b>	Switchable, (0 -20, -40 dB)
<b>Filter Type / Response:</b>	Switchable, low pass, -3 dB @ 30 kHz
<b>Dimensions HxWxD (in):</b>	1.85 x 4.6 x 3.9
<b>HxWxD (mm):</b>	47 x 117 x 99
<b>Weight (lbs/kg ):</b>	0.88 / 0.40

## **WARRANTY INFORMATION:**

### **Limited Warranty (USA only)**

Applied Research and Technology will provide warranty and service for this unit in accordance with the following warrants:

Applied Research and Technology, (ART) warrants to the original purchaser that this product and the components thereof will be free from defects in workmanship and materials for a period of **three** years from the date of purchase. Applied Research and Technology will, without charge, repair or replace, at its option, defective product or component parts upon prepaid delivery to the factory service department or authorized service center, accompanied by proof of purchase date in the form of a valid sales receipt.

### **Exclusions**

This warranty does not apply in the event of misuse or abuse of the product or as a result of unauthorized alterations or repairs. This warranty is void if the serial number is altered, defaced, or removed.

ART reserves the right to make changes in design or make additions to or improvements upon this product without any obligation to install the same on products previously manufactured.

ART shall not be liable for any consequential damages, including without limitation damages resulting from loss of use. Some states do not allow limitations of incidental

or consequential damages, so the above limitation or exclusion may not apply to you. This warranty gives you specific rights and you may have other rights, which vary, from state to state. The warranty terms listed above are only valid within the United States of America. For units purchased outside the United States, an authorized distributor of Applied Research and Technology will provide service. For information on warranty and service policies outside of the U.S., please contact your local distributor.

Please fill in the following information for your reference:

Date of purchase: \_\_\_\_\_

Purchased from: \_\_\_\_\_

## SERVICE:

The following information is provided in the unlikely event that your unit requires service.

1. Be sure that the unit is the cause of the problem. Check to make sure that the unit has power supplied, that all cables are connected correctly, and that the cables themselves are in working condition. You may want to consult with your dealer for assistance in troubleshooting or testing your particular configuration.
2. If you believe that the ART unit is at fault, go to [www.artproaudio.com](http://www.artproaudio.com). Select "Support", then "Return Authorization Request" to request a return authorization number.
3. If you are returning the unit for service, pack the unit in its original carton or a reasonable substitute. The original packaging may not be suitable as a shipping carton, so consider putting the packaged unit in another box for shipping. Print the RA number clearly on the outside of the shipping box. Print your return shipping address on the outside of the box.
4. Include with your unit: a note with the RA number and your contact information, including a return shipping address (we cannot ship to a P.O. box) and a daytime phone number, and a description of the problem, preferably attached to the top of the unit. Also include a copy of your purchase receipt.





**[www.artproaudio.com](http://www.artproaudio.com)**

**E-mail: [support@artproaudio.com](mailto:support@artproaudio.com)**

**© 2014 Applied Research & Technology**

**DUALZDirect**

**DZD-5004-101**

**V1.1**