



APPLIED RESEARCH AND TECHNOLOGY

TUBE CHANNEL

USER'S MANUAL

FEATURES.....	3
OVERVIEW.....	3
WHY USE AN EXTERNAL PROCESSING CHANNEL?	3
DESIGN NOTES.....	4
SETTING UP	5
UNPACKING	5
AC POWER HOOKUP.....	5
AUDIO CONNECTIONS.....	5
INSTALLATION	6
SAFETY PRECAUTIONS	6
POWERING UP	6
FRONT PANEL CONTROLS & INDICATORS	7
PREAMP CIRCUIT.....	7
<i>Gain Control</i>	7
<i>Gain Switch</i>	7
<i>Phantom Power Switch</i>	7
<i>Tube Drive/Gain Reduction Display</i>	8
<i>Preamp Output</i>	8
OPTICAL COMPRESSOR CIRCUIT.....	9
<i>Slope Switch</i>	9
<i>Speed Switch</i>	9
<i>Compressor Bypass Switch</i>	9
<i>Compressor Threshold and Output Controls</i>	10
<i>Compressor Threshold Control (outer control)</i>	10
<i>Compressor Output Level Control (inner Control)</i>	10
<i>Clip Indicator</i>	11
EQUALIZER CIRCUIT	11
<i>Low Frequency Control</i>	11
<i>Low Shift Switch</i>	11
<i>Lo-Mid Frequency Control</i>	12
<i>Lo-Mid Shift x 10 Switch</i>	12
<i>Hi-Mid Frequency Control</i>	12
<i>Hi-Mid Shift x 10 Switch</i>	12
<i>High Frequency Control</i>	12
<i>High Shift Switch</i>	13
<i>EQ Bypass Switch</i>	13
<i>Master Output Level Control</i>	13
<i>Phase Switch</i>	13

<i>Output Level VU Meter</i>	14
<i>Power</i>	14
REAR PANEL CONNECTIONS	15
INPUT AND OUTPUT CONNECTIONS	15
INPUT	15
OUTPUT.....	15
LOOP INSERTS.....	15
<i>Preamp - Compressor Loop</i>	16
<i>Compressor - EQ Loop</i>	16
<i>Loop Connections</i>	16
APPLICATIONS	17
SPECIAL EFFECTS	18
EQ TIPS	19
<i>What is the best way to use EQ?</i>	19
TUBE REPLACEMENT.....	20
BLOCK DIAGRAM.....	21
A R T TUBE CHANNEL SPECIFICATIONS	22
WE'RE ON-LINE!	23
WARRANTY AND SERVICE INFORMATION.....	23
LIMITED WARRANTY	23
SERVICE	23

Features

The Tube Channel is a unique product. It contains three independent award-winning circuit designs: one of the finest tube microphone preamplifiers available, one of the finest optical tube compressors available, and one of the most flexible EQs you've ever used -- all in one unit. Developed in partnership with studio and live sound engineers, the Tube Channel possesses a "sound" that is not available from any other product on the market -- at any price! The Tube Channel was designed and constructed with the best components, assuring a lifetime of quiet, reliable performance. The Tube Channel offers:- The award winning A R T "SOUND"! - A Tube-based mic/line preamplifier- An Electro-optical compressor design - A Tube-based semi-parametric, four-band equalizer- Hand-selected preamp tubes- VCA-less compressor circuitry (i.e., transparent dynamics control)- Unique tube drive and gain reduction metering - VU output level metering- Bypassable compression and equalization circuitry- XLR balanced inputs and outputs- 1/4" TS unbalanced inputs and outputs- A Custom extruded aluminum chassis - 1/4" unbalanced insert points between the preamp and compressor and between the compressor and equalizer- +48V phantom power- Phase reversal- Over 70dB of gain- Detented rotary controls- Compression and limiting ratios- Selectable release time settings- >90dB dynamic range- An Internal power supply- A three year warranty- The Tube Channel was Designed and manufactured in the USA

Overview

Why use an external processing channel?

The shortest signal path is the best way to get a signal to tape. In most cases, the shortest path is: mic to preamp to compressor to EQ to tape deck. The signal doesn't even go through the mixer! This isn't a new concept, but it has become more relevant with the availability of affordable mixing consoles. As their name implies, most affordable mixers excel in signal routing and mixing capabilities. However, they are not necessarily your best option for the actual recording of tracks. While their onboard circuitry is nearly always clean and quiet, the simple truth is that the Tube Channel has a better sounding and more

flexible collection of circuits. Mixer manufacturers need to make trade-offs to keep prices down while keeping performance up. Imagine the price of your mixer if each channels' EQ cost over \$200 (and we're not talking about those of you who have one of those \$250,000+ consoles!) The use of external processing (equalizers, preamps and compressors) has sonic and practical benefits when you consider that most recording is done one or two channels at a time. For those of us on a budget, it just doesn't make sense to spend a ton of money on a "Cadillac" console when a budget mixer and a few pieces of external gear is more cost effective. Even those engineers who regularly work on "big" consoles use external EQs, compressors and preamps! The goal of any recording is to get the sounds right before you commit them to tape. The Tube Channel exists to help you get it right so you don't have to "fix it in the mix".

Design Notes

The Tube Channel is a multi-purpose tool for audio engineering and recording. Enclosed in a one rack space (1U) chassis are three independent circuits featuring a tube-based analog preamplifier, a VCA-less, optical compressor, and a semi-parametric, four-band, tube-based equalizer. Used as a direct recording channel, a mic/line preamp, or a DI (direct) box, the Tube Channel is designed to work seamlessly with any recording, sound-reinforcement, or electronic instrument setup. A R T's Tube Channel circuitry is a hybrid design utilizing the latest, most advanced, solid-state and tube technology. With a transformerless design, the Tube Channel maintains exceptional signal integrity and extremely low noise. The compressor circuit follows the preamp and the equalizer follows the compressor (although you can change the order of the circuits by utilizing the insert points). While the preamp is always active, the compressor and equalizer may be individually bypassed. The preamplifier's active balanced solid-state input provides extremely low noise and excellent CMRR. The 1/4" input has a high impedance, which prevents the loading of any device connected to it and makes the Tube Channel perfect for DI or line level applications. The preamplifier's second stage 12AX7a tube runs on a regulated DC voltage providing an additional 40dB of gain. Our design enables the tube to overload before the input or output stage. This allows you to manipulate the tube gain to meet different sonic requirements. The compression circuit features a VCA-less design and utilizes optical (Vactrol) electronics for superior musical performance. The compressor is soft knee by design. Although it is capable of providing a thoroughly "squashed"

signal, it was designed to excel in areas where transparent and musical dynamics control is desired. The beauty of the optical design is its ability to apply heavy amounts of compression without pumping and breathing like VCA-based compressors. In many cases you will hear the results of the compression without hearing the compressor.

The tube-based equalizer was designed to help “fix” the instruments that give us the most headaches when we’re recording: kick, snare, bass, toms, guitar amps, voice, etc. The two sweepable parametric bands and selectable shelving bands have been optimized for musical instruments. The two sweepable bands overlap each other and also the high and low shelving bands, providing you with the ultimate in flexibility. This EQ design gives you all the control you need to effectively alter and dial in great sounds from even the poorest of sources.

Setting Up

Unpacking

Your Tube Channel was packed with care at the factory. The shipping carton was designed to protect the unit during initial shipment. Please retain this carton for use in transporting the Tube Channel, or in the unlikely event that you need to return your Tube Channel for servicing.

AC Power Hookup

The Tube Channel has an internal power supply designed to operate at 100 to 125VAC, 50 to 60Hz. Units manufactured for use outside of the United States have been modified to comply with the required electrical specifications. Under no circumstances should the power cable be altered. If the cable becomes cut or damaged, discontinue use and have it replaced before operating the Tube Channel.

Audio Connections

Audio connections to and from the Tube Channel are balanced XLR (Pin 2 = Hot (+), Pin 3 = Cold (-), Pin 1 = Ground) and unbalanced ¼” (Tip = Hot (+), Sleeve = Ground).

The insert points between the preamp and compressor and the compressor and equalizer are ¼” (Tip = Hot (+), Sleeve = Ground)

unbalanced connectors.

We recommend using only high-quality cables equipped with the appropriate connectors.

Installation

The Tube Channel may be employed in a number of setups including:-
Between a microphone and a mixer, digital multi-track recorder,
DAT machine, hard disk recorder, or analog recorder.- In a
mixer's channel insert points.- Between a microphone and signal
processors.- Between electronic musical instruments (synthesizers,
guitars, basses, samplers, acoustic instruments with pickups) and
other gear.

Safety Precautions

Warning: To avoid the risk of shock or fire, do not expose this unit to moisture. Do not remove metal panels or chassis parts. Removing any chassis parts exposes dangerous high voltages. There are no user-serviceable parts inside. Refer all servicing to qualified personnel.

Note: If your power cord becomes damaged and must be replaced, always replace it with the proper (3 prong) type.

Powering Up

When the power switch is turned on, the VU meter will illuminate. It is important to remember to turn the Tube Channel on *before* any monitoring levels or power amps are turned on. The Tube Channel has the ability to add over 60dB of gain to its input signal. This can cause the Tube Channel to produce a "thump" on power up and power down. Note: Like all tube-based equipment, the Tube Channel needs to warm up before being used. Allow one to two minutes for the tubes to reach proper operating temperature before using. If the Tube Channel fails to power up when the power switch is turned on, check to see that its power cord is plugged into an active outlet. If the unit still fails to operate properly, turn it off and unplug it. Then consult your dealer or A R T's Customer Service department.



Front Panel Controls & Indicators

Preamp Circuit

Gain Control

The Gain control sets the amount of input gain of the Tube Channel. Turn the control clockwise to increase gain and counterclockwise to decrease gain. Selection of the gain range is made with the +20dB gain switch. You may control two ranges of gain with this control, +9 to +50dB and -11 to +30dB. When setting the Gain control, refer to the 4 segment Tube Drive Array for a visual reference to the Tube Channel's internal signal levels (applied gain). **Hint:** the "sweet spot" for the Tube Channel is when the second "warm" Light Emitting Diode (LED) in the Tube Drive array is lit.

Gain Switch

Use the Gain switch to set the range of the Gain control. When the switch is in the out (0db) position the gain range is -11 to +30dB. Depressing the switch adds 20dB of gain. With the switch in, the gain range is +9 to +50dB. **Note:** With most microphone applications you'll find using the Tube Channel with the +20dB gain switch in is needed. Use the setting that best fits your application.

Phantom Power Switch

The Tube Channel can power any microphone needing +48 volts DC phantom power. Consult your microphone's documentation to see if phantom power is required to power it. Phantom power is turned on and off with this switch and supplies power to pins 2 and 3 of the XLR input jack.

Note: It is best to have phantom power turned off when connecting

microphones to the Tube Channel.**Note:** Be sure to turn down or mute the output of the Tube Channel when engaging or disengaging phantom power. Additionally, when disengaging, allow 30 - 45 seconds for the power to completely dissipate. Most microphones will make a sound like air leaking from a tire when phantom power is disconnected, but some can make some very nasty low rumbles and whines as well.**Another Note:** MOST dynamic microphones should not be affected or damaged if they are plugged into the Tube Channel when phantom power is turned on (we haven't run across any). However, if the mic doesn't need it, don't use it. Some things are best left untested!

Tube Drive/Gain Reduction Display

Four LEDs display how the tube gain is affecting the input signal. These LEDs are calibrated with the tube circuitry to give you an accurate representation of the tube's output signal (**Note:** these LEDs measure the signal level before the output level control). Use this meter as a visual guide for setting the Gain level. The first LED is labeled "Cln". The tube is producing a clean output when this LED is lit. The next two LEDs are labeled "warm." This is the optimal operating range for the Tube Channel's preamp. At this level, the tube is producing an output signal that most would term "warm" (Whatever you would like to call it is fine -- simmering, toasty, etc.) You'll find the output signal has an enhanced bottom to low mid quality with smooth high frequency detail. The last LED is labeled "Clip." This LED will light approximately 6dB before audible distortion occurs. If this light flickers, don't panic. The unique design of the Tube Channel allows the tube to distort well before any other gain stage. When a tube goes into distortion it is a gradual process and tends to sound pleasing for a range before it turns into a distortion box. After some use you'll find that the "sweet spot" of the Tube Channel is when this light flashes fairly regularly. You may very well find a "clipped" level is suitable for some applications.**Note:** Use the Tube Character Array to aid in setting the Gain Control.

Preamp Output

The Preamp Output control sets the output level of the preamp section of the Tube Channel. In most situations you'll be leaving this control set around 12 o'clock (or its "0" setting). The Preamp Output control has a range of no output (from its fully counter-clockwise position), to additional 16dB of gain (when turned fully clockwise).

When setting up the preamp circuit, start with the Preamp Output at its “0” level. Once you get the Gain control set the way you want it to sound, use the Preamp Output control to set the level out of the preamp circuit (much like using the master volume control on a guitar amplifier). Use the Preamp Output control to add more gain when you have the Gain control set low for a “clean” sound. Likewise, you can use the Preamp Output control to decrease the level out of the preamp circuit when you’re cranking the Gain control up for maximum tube warmth.

Optical Compressor Circuit

Slope Switch

The Slope Switch selects the compression ratio for the compressor circuit. In its “out” position, the compression ratio is an active 2.3:1. This means that for every 2.3dB over the threshold the input signal rises, the compressor’s output will change by 1dB. This is a very mild and musical compression ratio, which is ideal for smoothing all types of signals. In its “in” position, the compression ratio is greater than 6:1. This is typically called “soft limiting” as it allows only a 1dB change in signal level for any signal reaching over 6dB of the set threshold. This setting is ideal for applications where exceeding a set level is not desirable (i.e., mixing, popping bass, digital recording, etc.).

Speed Switch

The position of the Speed switch selects the release characteristics of the compressor circuit. The “out” (“fast”) position allows the compressor to recover quickly once the signal falls below the threshold. The “in” (“auto”) position allows the compressor to adjust itself depending on the characteristics of the input signal. Use the “fast” setting when the signal has repetitive, consistent characteristics (kick drum, snare, vocals, etc.). Use the “auto” setting when the signal has varying characteristics (long decaying notes alternating with quick notes, mix material, etc.).

Compressor Bypass Switch

A Bypass switch is included on the compressor circuit to enable you to remove the compressor from the signal chain. When set to its “in”

(bypass) position, signal is allowed to pass from the preamp circuitry to the equalizer circuit with no compression. The LED will glow red when Bypass is engaged. This informs you that the compressor is bypassed. In its “out” (Norm) position, the compressor is active.

Use the Bypass switch when setting the compressor’s output level to achieve unity (no boost or cut) gain. Unity gain is achieved through the compressor when the active level is the same as the bypassed level. Toggle the switch between active and bypass while adjusting the compressor output level. Once the levels are the same (use your ears and the VU Output Level meter), you’ve reached the unity setting for the compressor.

Compressor Threshold and Output Controls

The compressor’s Threshold and Output controls are ganged together on a dual concentric pot. The outer control is the Threshold level and the inner control is the Output level.

Compressor Threshold Control (outer control)

The Threshold control sets the point at which the compressor circuit will act on the input signal. Turning this control counterclockwise lowers the threshold (adding more compression to a signal). Turning this control clockwise raises the threshold. Setting the Threshold control is dependent on the Preamp Output control (or the output of the device plugged into the compressor return insert point). The easiest way to set the threshold control is to start with the control fully clockwise. After setting the Preamp Output control, slowly turn the Threshold control counter-clockwise (lowering threshold) until you see the yellow (0dB) Threshold LED light in the gain reduction display. Now adjust the control (either lower or higher) until you have the amount of compression you desire. Use the Gain Reduction meter as a visual guide to the amount of compression applied.

Compressor Output Level Control (inner Control)

The Compressor Output level control sets the output level from the compressor circuit. Typically, the output level of a compressor is used to add gain to compensate for the amount of compression applied to a signal. The output level is set to achieve unity gain (no change in level when compressor is active or bypassed). *See Compressor Bypass Switch for more details on achieving unity gain.*

When the control is fully counter-clockwise, the output is attenuated by -20dB . Turning the control clockwise increases the level to a maximum of $+20\text{dB}$ of gain. While you can use the compressor to add gain to a signal, it is better to add gain before the compressor for the best signal to noise ratio. If you want to use the compressor to add more gain, refer to the output level VU meter, or the meter on your recorder or mixer to make sure you won't clip the next piece of equipment in the chain.

Clip Indicator

The Clip LED is located in the equalizer circuit. It will illuminate 6dB before the headroom of the circuit is exceeded. When this Clip indicator lights, the level *into* the equalizer is too high. Turn down either the Preamp Output control, the Compressor Output control or the output level of the device plugged into the compressor return insert point.

Equalizer Circuit

The equalizer circuit in the Tube Channel is a tube--based, semi-parametric, four-band equalizer. Each of the bands overlap, giving you the ultimate in flexibility. The "Q" (or bandwidth) of each of the filters is purposely wide to provide a very musical sound.

Low Frequency Control

The Low Frequency control adjusts a shelving filter with a selectable corner frequency of either 40Hz or 120Hz . The low shelving filter affects all frequencies below the corner frequency when applying boost or cut. In other words, cutting at 40Hz also cuts 30Hz , 20Hz , etc. The Low Frequency control has a range of $\pm 12\text{dB}$. Two ranges are selected with the Low Shift Switch: 40Hz or 120Hz . 40Hz is great for enhancing sub-low frequencies such as those in bass guitars and kick drums. Cutting 40Hz can also help to "clean up" mixes that sound muddy or "loose" in the low end. 120Hz is generally the low-end for vocals, guitars and toms. Boosting 120Hz can add "weight" or "beef" to a weak vocal and cutting it can "thin out" a signal that takes up too much room in the low end.

Low Shift Switch

The Low Shift switch selects the corner frequency of the Low Frequency control. In the "out" position the corner is 40Hz . In the "in"

position the corner is 120Hz.

Lo-Mid Frequency Control

The Lo-Mid control is a dual concentric pot (there are two controls--one outer and one inner). The outer control is used to select a frequency while the inner control is used to apply +/-12dB of gain. The Lo-Mid control can cover two frequency ranges depending on the position of the Shift x 10 switch. These ranges are 20Hz to 200Hz and 200Hz to 2KHz.

Lo-Mid Shift x 10 Switch

The Lo-Mid Shift x 10 switch determines the range over which the Lo-Mid frequency control will cover. In its "out" position, the range is set at 20Hz to 200Hz. In its "in" position the range is set at 200Hz to 2KHz.**Note:** You'll notice the Low Frequency and Lo-Mid Frequency controls overlap (meaning they cover the same frequencies). This is intentional and is one of the powerful features of the equalizer circuit.

Hi-Mid Frequency Control

Like the Lo-Mid Frequency control, the Hi-Mid control is a dual concentric pot (there are two controls--one outer and one inner). The outer control is used to select a frequency while the inner control is used to apply +/-12dB of gain. The Hi-Mid control can cover two frequency ranges depending on the position of the Shift x 10 switch. These ranges are 200Hz to 2KHz and 2KHz to 20KHz.

Hi-Mid Shift x 10 Switch

The Hi-Mid Shift x 10 switch determines the range over which the Hi-Mid Frequency control will cover. In its "out" position the range is set at 200Hz to 2KHz. In its "in" position the range is set at 2KHz to 20KHz.**Note:** The Lo-Mid and Hi-Mid Frequency controls overlap in the 200Hz to 2KHz range. This feature allows either or both controls to be used in this range. This is extremely useful if you want to cut at 200Hz and boost at 350Hz.

High Frequency Control

The High Frequency control adjusts a shelving filter with a selectable corner frequency of either 6KHz or 18KHz. The high shelving filter affects all frequencies above the corner frequency when applying boost or cut. In other words, cutting at 6KHz also cuts 7KHz, 8KHz, etc.

The High Frequency control has a range of +/- 12dB. The two ranges are selected with the High Shift switch. 6KHz is great for adding top end to guitars, snare drums and vocals. Cutting 6KHz can also help to “take the edge off” brittle or harsh sounding instruments. 18KHz may be used to add “sizzle” to cymbals and is generally referred to as the “air” band. While there aren’t very many instruments that contain 18KHz information directly, many instruments and mixes contain upper harmonics, which can add extra definition and “space” when boosted. Cutting at 18KHz can decrease hiss and noise.

High Shift Switch

The High Shift switch selects the corner frequency of the High Frequency control. In the “out” position the corner is 18KHz. In the “in” position the corner is 6KHz. **Note:** The High Frequency and Hi-Mid Frequency controls overlap. This feature gives you the ultimate in flexibility. For example, on cymbals try boosting 18KHz with the High control while cutting 20KHz with the Hi-Mid control for a very bright, yet noise-free result.

EQ Bypass Switch

A Bypass switch is included in the equalizer circuit to enable you to remove it from the signal chain. When set to its “in” (bypass) position, signal is allowed to pass from the compressor circuitry to the output jacks with no equalization. The LED will glow red when Bypass is engaged. This informs you that the equalizer is bypassed. In its “out” position, the equalizer is active. Use the EQ Bypass switch when setting the Tube Channel’s output level to achieve unity (no boost or cut) gain through the equalizer circuit. Unity gain is achieved when the active level is the same as the bypassed level.

Master Output Level Control

The Master Output level control sets the output level of the Tube Channel. When the control is fully counterclockwise, there is no output. Turning the control clockwise increases the level of the output to a maximum of +10dB of gain. When setting the Output Level control, refer to the VU Output Level meter or the level meter on your recorder or mixer.

Phase Switch

The Phase switch is provided to reverse the phase of signal leaving the

Tube Channel's XLR Output jack. The Phase switch also reverses the polarity of the 1/4" Output jack. In the Normal (out) position, the signal is in-phase. In the Reverse (in) position, the polarity of Pins 2 and 3 (and the Tip of the 1/4" jack) are reversed and the signal is changed to 180 degrees out of phase with the input signal. In multiple microphone applications, the placement of the microphones can affect the phase of a signal. If two microphones pick up the same signal from different locations, the result can be a hollow or frequency "shifted" sound. In some cases it may sound as if an instrument disappears if it happens to be 180 degrees out of phase. Depressing the Phase switch can remedy this problem. Likewise, if a microphone cable is wired incorrectly, the signal will be also out of phase. **Note:** In single microphone applications, switching the phase will produce no audible change in the output signal.

Output Level VU Meter

A backlit, average reading, VU meter is provided to accurately monitor the output level of the Tube Channel. The "0" level is calibrated to +4dBm with a 600 ohm load on the output (using *either* the XLR or 1/4" connector).

Use the VU meter for a visual reference to the signal level leaving the Tube Channel.

Note: When using the Tube Channel into a mixing console or recorder, always reference the meter on the mixer or recorder when setting output levels. All meters are not necessarily calibrated the same and it is always best to look at the level entering the last piece of equipment in the chain.

Power

The Power switch supplies and removes power from the Tube Channel. The Tube Channel should be turned "on" only *after* all monitor levels are turned down, or off, to protect against any "thumping" caused by high gain settings. Likewise, the Tube Channel should be turned "off" *after* turning all monitor levels down.

The Output Level VU meter will illuminate when power is turned on.

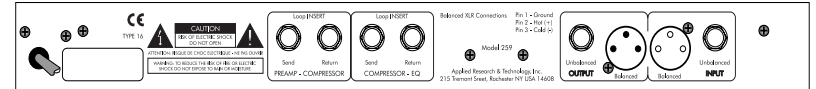

Rear Panel Connections

Input and Output Connections

The Tube Channel's XLR connectors follow the AES standard: Pin 1 = Ground, Pin 2 = Hot (+), Pin 3 = Cold (-). The unbalanced 1/4" phone jacks are typical Tip = Hot (+), Sleeve = Ground.

Input

One input jack per channel should be used at a time. However, because of its design, the Tube Channel *can* be hard-wired without having to disconnect the XLR inputs when using the 1/4" jacks. If no load is placed on the XLR input (no instrument or microphone connected) the 1/4" jack will function as if there was nothing connected to the XLR input. However, it is still preferable to disconnect any unused cables to avoid pick up of extraneous noise, hum, or RF interference.

Output

Both balanced and unbalanced output connections may be used simultaneously. This is particularly useful when using the Tube Channel as a direct box for instruments or line level signals. **Note:** If you experience a hum when using both output connectors simultaneously (one to the console and one to an instrument amp), a ground loop may be the problem. To remedy this problem, disconnect the ground wire (pin 1) from the XLR cable plugged into the Tube Channel's output (or use a ground-lifted audio cable). This interrupts the ground path and therefore breaks the loop.

Loop Inserts

Two signal loops are provided to connect external equipment to the Tube Channel, to use only specific individual circuits, or to take direct

signal paths from specific sections. The connections are unbalanced ¼" (Tip = Hot (+), Sleeve = Ground). Both of the "send" jacks may be used without interrupting signal-flow through the Tube Channel. The "return" jacks break the signal-flow when a jack is inserted.

The loops may also be utilized to "re-patch" the compressor and equalizer circuits in a different order (i.e. signal flow = preamp *to* equalizer *to* compressor).

Preamp - Compressor Loop

A loop is provided between the output of the preamp circuit and the input of the compressor circuit. The Preamp Send jack is located directly *after* the Preamp Output level control. This jack may be used to send an unbalanced signal directly to an input of a recorder, mixer or other piece of outboard equipment.

The Compressor Return jack is located directly *before* the Threshold Control of the compressor circuit. This jack may be used to connect the output of a piece of equipment to the input of the compressor circuit in the Tube Channel. Since there is no input level control to the compressor in the Tube Channel, the piece of equipment in the insert loop should have level matching capabilities (i.e., an output level control).

Compressor - EQ Loop

A loop is provided between the output of the compressor circuit and the input of the equalizer circuit. The Compressor Send jack is located directly *after* the Compressor Output level control. This jack may be used to send an unbalanced signal directly to an input of a recorder, mixer or other piece of outboard equipment.

The EQ Return jack is located directly *before* the input of the equalizer circuit. This jack may be used to connect the output of a piece of equipment to the input of the equalizer circuit in the Tube Channel. Since there is no input level control to the equalizer in the Tube Channel, the piece of equipment in the insert loop should have level matching capabilities (i.e., an output level control).

Loop Connections

To use only the preamp of the Tube Channel: Plug a mic, instrument, or line level signal into either of the Input Jacks. You can use *either* of

the following for an output: Plug the output from the Preamp Send jack into the input of the next piece of equipment, - or - bypass the compressor and equalizer circuits and connect either of the Output Jacks to the input of the next piece of equipment.

To use only the compressor circuit of the Tube Channel: Plug a line level signal (or a *send* from a mixer) into the Compressor Return Jack. Connect the output from the Compressor Send jack into the input of the next piece of equipment (or the *return* of a mixer).

To use only the equalizer circuit of the Tube Channel: Plug a line level signal (or a *send* from a mixer) into the EQ Return Jack. Connect either output from the Tube Channel into the input of the next piece of equipment (or the *return* of a mixer).

To place the equalizer circuit before the compressor circuit: Connect the Preamp Send to the EQ Return. Connect the unbalanced Output to the Compressor Return. Use the Compressor Send as the main output to the input of the next piece of equipment.

Applications

The main application of the Tube Channel is as a processing channel for a microphone, instrument or line level source. To use the Tube Channel as a mic or line preamplifier only, simply press the Bypass switches to bypass the compression and equalizer circuitry. Plug a microphone directly into either input and set the input and output controls to provide an appropriate level into the next stage of your system. The Tube Channel is ideal for use as a DI box. Plug the instrument into either input and use the XLR, 1/4, or both outputs to connect to your recorder, board, or PA system. Experiment with different input level settings for different textures.

In most cases the Tube Channel offers superior performance to the on-board preamp on your console. To use the Tube Channel instead of your on-board preamp, simply connect the output of the Tube Channel to the line input of your mixer's input channel. Note: you can connect the XLR output jack of the Tube Channel to the XLR input of your mixer, however most affordable mixers do not allow you to bypass their internal preamp when using the XLR jack. You will cause no harm to either unit when doing this but you will probably experience slightly higher noise. This is due to the fact that you are now preamplifying your mixer's preamp.

Note: Be certain that you **do not** connect the Tube Channel's XLR Output to a mixer input that has Phantom Power applied.

The Tube Channel has enough gain to be used in front of a power amplifier. To use the Tube Channel as a instrument preamp, simply plug the instrument into the Input jack and connect the Output jack to the input of the power amplifier. See *Loop Connections* for further hook-up options and for using single circuits in the Tube Channel.

Special Effects

For industrial, metal, or just “flavor” textures, experiment with the Tube Channel. Overdriving the preamp, compressor and equalizer circuitry can add interesting textures when blended with vocals and other instruments. Placing signals purposely out of phase can also yield interesting results. No harm will come to the Tube Channel with this type of experimentation. However, be sure to have output and monitoring levels turned DOWN before “testing” the sound. Remember, you have a great amount of gain available in the Tube Channel!

EQ Tips

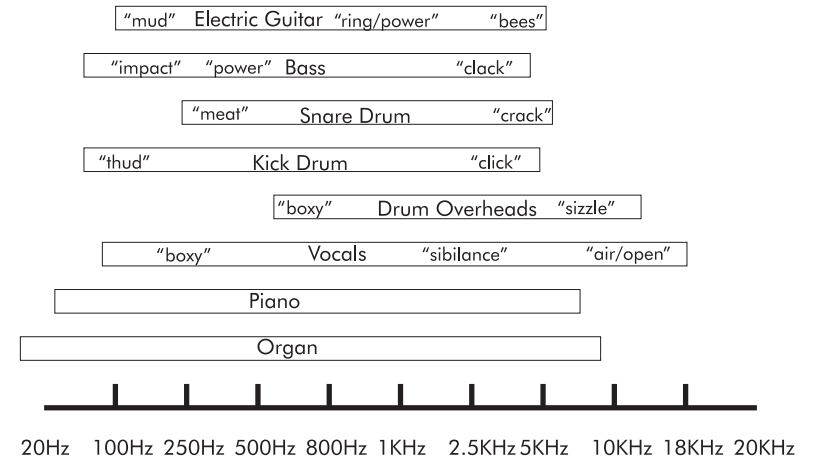

What is the best way to use EQ?

There are two schools of thought on EQ: 1) Use as much as you need to make things sound good. 2) Don't use any EQ. Most people follow the suggestion of "if it sounds good, it is good." You need to use your ears and judge for yourself as there are no steadfast rules for EQing. Here are a few pointers to guide you. Always tweak the instrument you are EQing while listening to it in the mix. EQ'ing an instrument when it is soloed doesn't give you a good representation of how it will sound when mixed with other instruments. You'd be surprised at how bad a killer guitar track can sound when it is isolated from the rest of the mix. Remember, what makes it killer is how it sounds in relation to the other instruments! Always keep the big picture in mind. Most people think of EQ as boosting only ("we'll just add a little EQ..."). Many times a "bad" sounding instrument can be fixed by simply isolating the bad frequency and pulling it out. After you determine approximately where the "problem area" is in the instrument (highs, lows, mids), isolate the track and boost one of the mid bands. Slowly sweep through the frequency range. When the really nasty sound jumps out at you (you'll know it when it happens) turn the boost back to "0" (12 o'clock). Now put the track back into the mix and cut the

frequency. You'll have to adjust the level of the instrument depending on how much you cut, but you should find that with the "problem area" pulled out, the instrument works better in the mix. When recording EQ'd instruments you want to make sure you have good representation of frequencies on tape. Always monitor "off" tape when recording. This ensures that what you're hearing is what is on tape. When recording things like kick drums, make sure you have enough low end "thud" and high end "click" (if applicable) before you record. Recording guideline: You can always boost or cut frequencies after they've been recorded, but you can't add frequencies that weren't recorded! Always be prepared for the drummer who says he loves the John Bonham kick drum sound (lots of low end power and ambiance) you got when recording but during the mix decides he wants to sound like Metallica (more click than punch). If you get the sounds right when you record the tracks you shouldn't be spending a lot of time re-EQing during the mix. During mixing you should be concentrating on the blending of tracks and the dynamics of the song. If you find yourself EQing everything, take a break and come back to it later. Start mixing with a group of instruments (the whole drum kit or guitars and bass) instead of listening to individual tracks. Mixing is the time for tweaking -- not applying a sonic re-design. Once again, "if it sounds good, print it!" Trust your ears -- nevermind where the knobs are pointing.

Tube Replacement

The Tubes in your Tube Channel should last for many years. They are hand-sorted for performance. In the event that you need to replace them, A R T suggests that you do so with tubes available from A R T. These are matched to the Tube Channel and will yield consistent sonic results. You can replace the tubes with other brands, however A R T has no responsibility for the resulting sound quality. They may sound better, they may sound worse. The choice is yours. Please realize that unauthorized alterations to the Tube Channel will result in voiding the warranty.

BLOCK DIAGRAM - Tube Channel

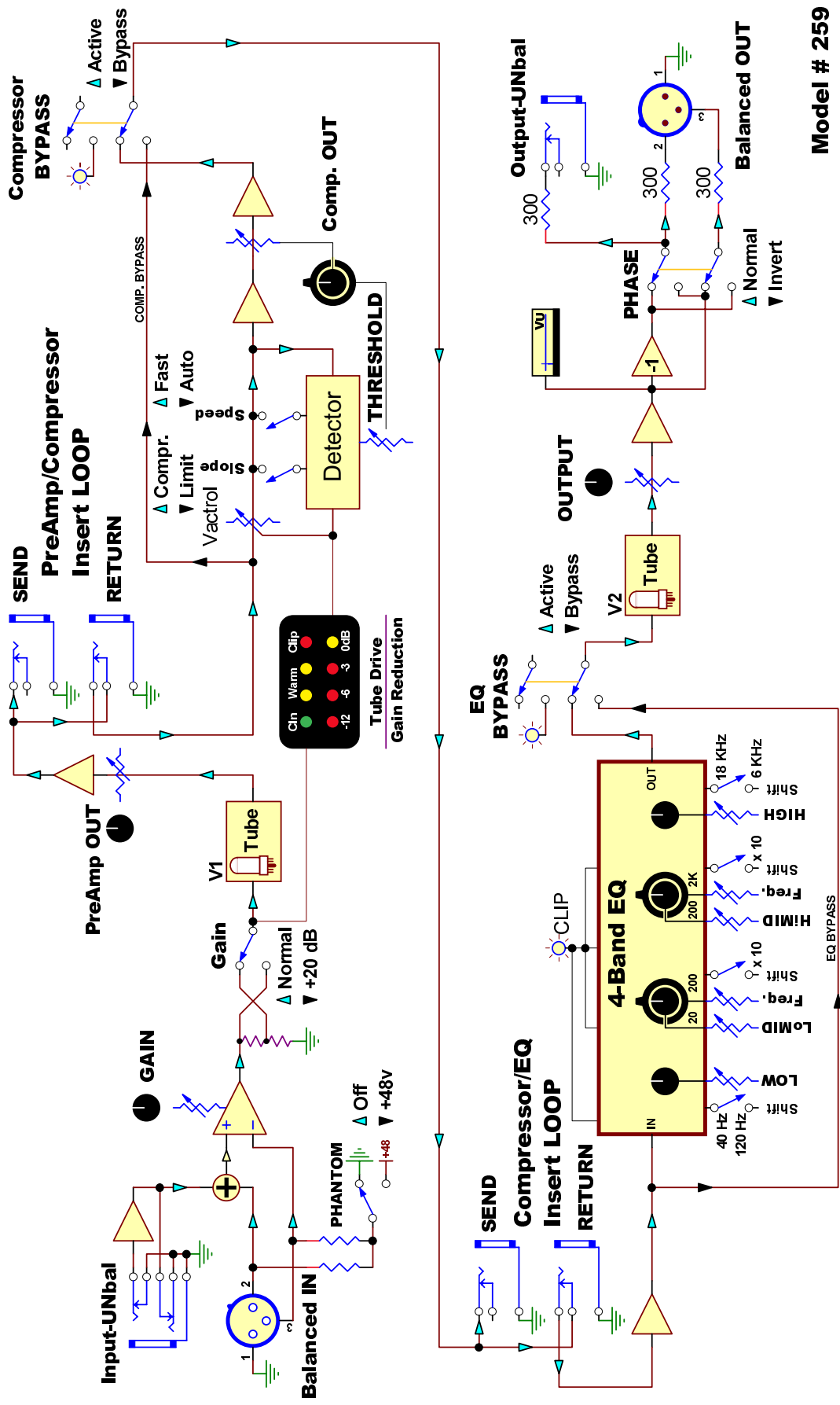

Model # 259

A R T Tube Channel Specifications

Dimensions	5.25"D x 19"W x 1.65"H
Weight	8.0 lb.
Maximum Gain	
XLR to XLR	81dB
¼" to ¼"	63dB
Phantom Power	+48v DC (switchable)
Compression Ratio	2.3:1 (comp)/ 6:1 (lim)
Attack Time	6.5ms
Release Time	200ms (fast), 70ms-1sec (auto)
EQ Frequency Bands:	
Low Shelf:	40Hz/120Hz Selectable
High Shelf:	6KHz/18KHz Selectable
Low-Mid Sweepable:	20Hz to 200Hz/ 200Hz to 2KHz
High-Mid Sweepable:	200Hz to 2KHz/ 2KHz to 20KHz
"Q"	1.1
Gain/Frequency Band:	+/- 12dB
Equivalent Input Noise	-129dBu (XLR to XLR, 'A' wghtd)
Dynamic Range	>90dB (no weighting)Input
Impedance	1.67k ohms (XLR), 1M ohm (¼")
Output Impedance	600 ohms (XLR), 300 ohms (¼")
Maximum Input Level	+15dBu (XLR), +21dBu (¼")
Maximum Output Level	+27dBu (XLR), +22dBu (¼")
CMRR	90dB (typical)
THD	<0.1% (typical)
Tubes	Two Hand-Selected Tubes (12AX7A/12AT7)
Power Requirements	100-125 VAC, 25W (Export units configured for country of destination)

A R T retains a policy of constant product improvement. A R T reserves the right to make changes in design or make additions to or improvements upon this product without any obligation to install the same on products previously manufactured. In other words, specifications are subject to change without notice.

Designed and manufactured in the United States of America.

Applied Research and Technology, Inc. (716) 436-2720 (Phone)

215 Tremont Street
Rochester, NY 14608 USA

(716) 436-3942 (FAX)

We're on-line!

For Product information, questions, applications, tips, answers and general discussion with A R T employees look for A R T on the Internet.. Email us at artroch@aol.com Check out our Web Page at: <http://www.artroch.com>

Warranty and Service Information

Limited Warranty

Applied Research and Technology, Inc. will provide warranty service for this unit in accordance with the following warranty statement. Applied Research and Technology, Inc. (A R T) warrants to the original purchaser that this product is free from defects in workmanship and materials for a period of three years from the date of purchase. A R T will, without charge, repair or replace, at its option, defective product or component parts upon prepaid delivery to the factory service department or an authorized service center, accompanied by proof of purchase date in the form of a valid sales receipt. EXCLUSIONS: This warranty does not apply in the event of misuse or abuse of the product or as a result of unauthorized alterations or repairs. This warranty is void if the serial number is altered, defaced or removed.

A R T reserves the right to make changes in design and make additions or improvements upon this product without any obligation to install the same on products previously manufactured. A R T should not be liable for any consequential damages, including without limitation damages resulting from the loss of use. Some states do not allow limitation of incidental or consequential damages, so the above limitation or exclusion may not apply to you. This warranty gives you specific rights and you may also have other rights, which vary, from state to state. For products purchased outside the United States, service will be provided by an authorized distributor of Applied Research and Technology, Inc. products.

Service

The following information is provided in the unlikely event that your unit requires service. Use this procedure to return units in the United

States only. For service outside the United States, please contact your authorized A R T distributor.1) Be sure the unit is the cause of the problem. Check to make sure the unit has power supplied, all cables are connected correctly, and the cables themselves are in working condition.2) If you find the unit to be at fault, write down a description of the problem, including how and when the problem occurs.3) Call the factory for a Return Authorization (RA) number.4) Pack the unit in its original carton or reasonable substitute. The packing box is not recommended for a shipping carton. Put the packaged unit in another box for shipping. Print the RA number clearly under the address.5) Include with your unit: a return shipping address (we cannot ship to a P.O. Box), a copy of your purchase receipt, a daytime phone number and the description of the problem.

6) Ship the unit to:

Applied Research and Technology, Inc.
215 Tremont Street
Rochester, NY 14608
Attn: Repair Department
R.A.# _____

7) Contact our Customer Service department at (716) 436-2720 for your Return Authorization number or questions regarding your repair. Customer Service hours are Monday through Friday 9:00AM to 5:00PM Eastern time.

©1998 Applied Research and Technology, Inc.