



# Tubeopto 8™

8-CHANNEL TUBE MICROPHONE  
PREAMPLIFIER / OPTICAL INTERFACE

## USER'S GUIDE



# IMPORTANT SAFETY INSTRUCTIONS – READ FIRST



This symbol, wherever it appears, alerts you to the presence of uninsulated dangerous voltage inside the enclosure. Voltage that may be sufficient to constitute a risk of shock.



This symbol, wherever it appears, alerts you to important operating and maintenance instructions in the accompanying literature. Please read manual.

## **Read instructions:**

Retain these safety and operating instructions for future reference. Heed all warnings printed here and on the equipment. Follow the operating instructions printed in this user guide.

## **Do not open:**

Aside from four vacuum tubes, there are no user serviceable parts inside. Refer any service work to qualified technical personnel only.

## **Power sources:**

Only connect the unit to mains power of the type marked on the rear panel. The power source must provide a good ground connection.

## **Power cord:**

Use the power cord with sealed mains plug appropriate for your local mains supply as provided with the equipment. If the provided plug does not fit into your outlet consult your service agent. Route the power cord so that it is not likely to be walked on, stretched or pinched by items placed upon or against.

## **Grounding:**

Do not defeat the grounding and polarization means of the power cord plug. Do not remove or tamper with the ground connection on the power cord.

## **Ventilation:**

Do not obstruct ventilation or position the unit where the air required for ventilation is impeded. If the unit is to be operated in a rack, case or other furniture, ensure that it is constructed to allow adequate ventilation.

## **Moisture:**

To reduce the risk of fire or electrical shock do not expose the unit to rain, moisture or use in damp or wet conditions. Do not place a container of liquid on it, which may spill into any openings.

## **Heat:**

Do not locate the unit in a place close to excessive heat or direct sunlight, as this could be a fire hazard. Locate the unit away from any equipment, which produces heat such as: power supplies, power amplifiers and heaters.

## **Environment:**

Protect from excessive dirt, dust, heat, and vibration when operating and storing. Avoid tobacco ash, drink spillage and smoke, especially that associated with smoke machines.

## **Handling:**

To prevent damage to the controls and cosmetics avoid rough handling and excessive vibration. Protect the controls from damage during transit. Use adequate padding if you need to ship the unit. To avoid injury to yourself or damage to the equipment take care when lifting, moving or carrying the unit.

## **Servicing:**

Switch off the equipment and unplug the power cord immediately if it is exposed to moisture, spilled liquid, objects fallen into opening, or the power cord or plug becomes damaged during a lightning storm or if smoke odor or noise is noted. Refer servicing to qualified technical personnel only.

## **Installation:**

Install the unit in accordance with the instructions printed in the user guide.

# The ART Tubeopto 8™

## 8-Channel Tube Microphone Preamp Interface

IMPORTANT SAFETY INSTRUCTIONS – READ FIRST .....	II
INTRODUCTION .....	1
INSTALLATION.....	1
AC Power Hookup.....	1
Analog Audio Connections .....	1
CONTROLS and JACKS.....	2
FRONT PANEL .....	2
Instrument Input .....	2
Gain Control .....	2
Pad Switch .....	2
+48V Switches.....	3
Phase Switch.....	3
Low Frequency Rolloff Switch .....	3
LED Level Meter.....	3
Output Control.....	3
Output Source Switches .....	3
Sample Rate / Sync Switch .....	3
Sample Rate / Sync LEDs.....	4
Power Switch.....	4
REAR PANEL.....	4
Balanced Input Jacks – XLR & 1/4" TRS Combo Jacks .....	4
Balanced Output Jacks.....	4
Output Level Switch .....	4
Wordclock Input and Thru Jacks .....	5
ADAT Lightpipe Jacks .....	5
HARDWARE OPERATION .....	6
How to adjust the preamplifier controls for the lowest noise.....	6
How to set the Output Level switch (on the rear panel).....	6
Changing the sample rate .....	6
Using the Wordclock input.....	7
APPLICATIONS.....	8
Typical applications .....	8
Troubleshooting.....	9
WARRANTY INFORMATION .....	10
SERVICE .....	11
Tubeopto 8™ SPECIFICATIONS.....	12

### List of Figures

FIGURE 1 - Input Channel.....	2
FIGURE 2 – Output and Sample Rate Section.....	3
FIGURE 3 - Rear Panel .....	4
FIGURE 4 - Block Diagram.....	5
FIGURE 5 - Wordclock Connections .....	7



# CONTROLS and JACKS

## FRONT PANEL

### Instrument Input

The 1/4" TS (Tip Sleeve) jack on the front panel provides a high impedance unbalanced input and, when used, automatically switches off the mic preamp section. (The rear combo jack's 1/4" TRS (Tip Ring Sleeve) balanced input is lower impedance and is part of the mic preamp. The rear jack is not intended to be used with high impedance microphones or instruments.) NOTE: The PAD switch is disabled and **DOES NOT** affect gain when using the Instrument input.

### Gain Control

This control adjusts both the mic preamp gain as well as the instrument input gain. The gain markings apply to the mic preamp without the Pad switch depressed. (The instrument input gain is lower than the markings.) Please refer to the **HARDWARE OPERATION** section to learn how to optimize the gain control for low noise operation.

### Pad Switch

This switch reduces the mic preamp gain to prevent clipping when high-level microphone or line level signals are applied to the rear panel XLR / 1/4" TRS combo jack input. This switch does NOT affect the instrument input.

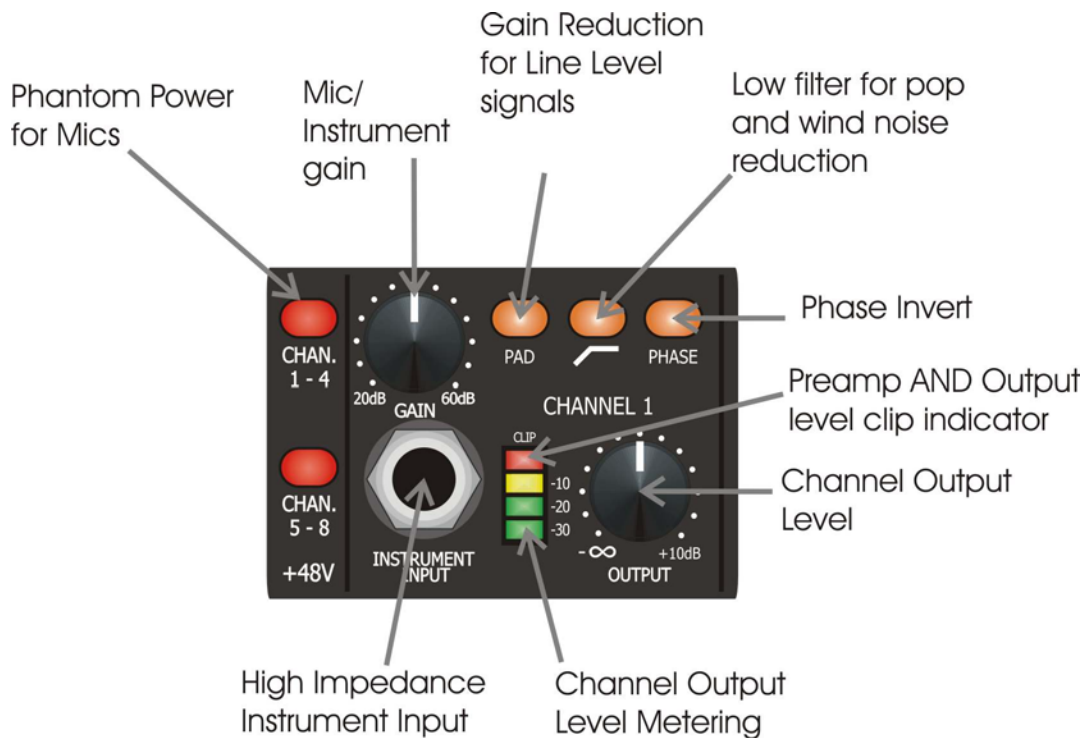

FIGURE 1 - Input Channel

## +48V Switches

These switches provide phantom power to each set of four XLR inputs. Use phantom power only when the microphone you are using requires it. This can extend the life of the Tubeopto 8™ as well as reduce the possibility of a shock hazard.

## Phase Switch

This switch selects the output phase of each channel. There is a 180-degree phase inversion through the channel when the switch is lit.

## Low Frequency Rolloff Switch

This switch inserts an 80Hz, 1-pole High Pass Filter (HPF) into the signal path. The filter is designed to remove rumble, pops, and wind noise, yet still sound natural.

## LED Level Meter

The four-segment LED level meter indicates the signal level at the input of the A/D converter. In addition to monitoring the A/D level, the CLIP LED monitors all of the gain stages within the preamp channel for clipping.

## Output Control

The output control provides gain or attenuation to adjust to a variety of system operating levels. This control sets the level sent to the A/D converter.

## Output Source Switches

The Output Source switches select the signal source sent to the analog TRS outputs on the rear panel. Depressing a switch selects a pair of channels, and sends a line level signal from the preamp, to the corresponding output jacks. In the "out" position, the signal is from the ADAT input (D to A).

## Sample Rate / Sync Switch

This switch cycles through all of the various sample rates available to the Tubeopto 8™. Holding the switch down will automatically cycle through the available settings.

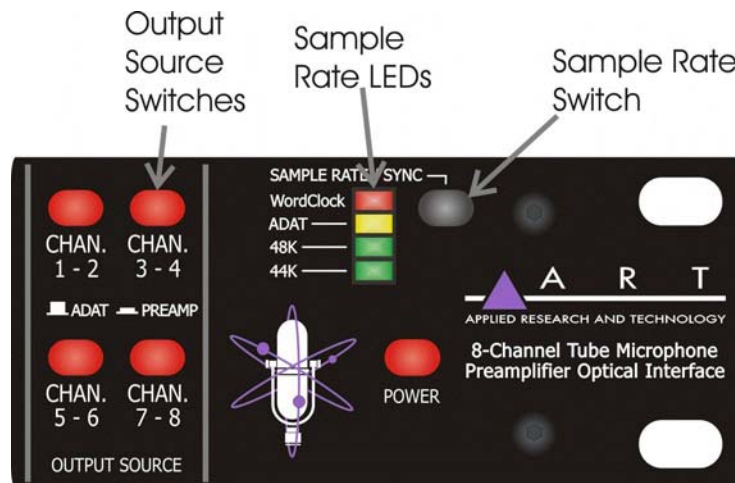

FIGURE 2 – Output and Sample Rate Section

## Sample Rate / Sync LEDs

This display indicates the rate and source of the A/D converter sample rate. (The D/A sample rate is independent of this setting as it always slaves to the incoming ADAT data).

The ADAT LED will flash if there is no incoming ADAT data, or if there is a data error. This is independent of the sample rate selected.

Selecting Wordclock will light the red Wordclock LED. This LED will flash if the Tubeopto 8™ cannot use this input as a sync source. This LED will only flash if Wordclock mode is selected.

## Power Switch

This switch controls and indicates that the unit is powered up and operational. When dimly lit, it indicates a low power source or an internal problem.

## REAR PANEL

### Balanced Input Jacks – XLR & 1/4” TRS Combo Jacks

These balanced inputs are used for both microphone and line level signals. The gain sensitivity is identical for both the XLR and 1/4” TRS jacks, however the XLR input impedance is 6.4K Ohms and the 1/4” TRS input impedance is 20K Ohms. The front panel Pad switch varies the sensitivity of both inputs.

### Balanced Output Jacks

Eight low impedance 1/4” TRS balanced output jacks provide audio output from the D/A converters or the preamps as selected by the Output Source switches.

### Output Level Switch

This switch optimizes the output level of the rear output jacks with your system operating level. Depress the switch when connected to +4dBu systems. In this case the maximum output is +20dBu when the digital level equals 0 VU.

When the switch is in the “out” position, the output levels are optimized for –10dBV systems.

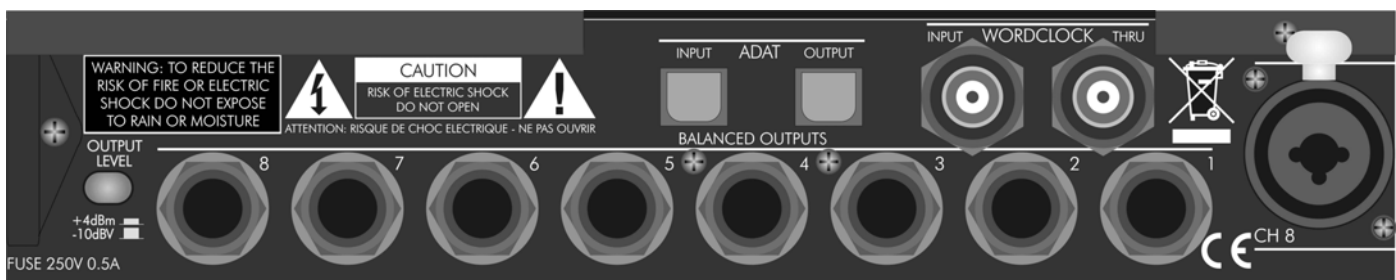

FIGURE 3 - Rear Panel

## Wordclock Input and Thru Jacks

The Wordclock input is used to externally sync the Tubeopto 8™ to a master clock source. The BNC Wordclock Input jack is connected directly to the BNC Wordclock Thru jack, providing the ability to loop through the Tubeopto 8™ and connect other devices to the Wordclock sync source, eliminating the need for a BNC T–adapter.

The Wordclock input is high impedance thus leaving the Wordclock connection **unterminated**. This allows for looping Wordclock through multiple units. A 75 Ohm BNC terminator should be used on the Wordclock Thru jack if only the Wordclock Input jack is used. Page 7 (Using the Wordclock input) goes into more detail on Wordclock termination. Proper termination is important as it reduces the reflections from the undriven end of a cable. These reflections can skew the timing of the waveform leading to timing errors.

## ADAT Lightpipe Jacks

Each ADAT Lightpipe jack supports eight channels of 24 bit digital audio data conforming to the ADAT Lightpipe protocol, which transfers eight tracks over a single fiber optic cable. Sample rates of 44.1KHz and 48KHz are supported by this standard.

The ADAT Lightpipe Output jack data is generated by the eight internal A/D converters that are directly driven by the outputs of the eight preamplifier channels. The A/D sample rate and sync source are selected by the front panel switch.

The ADAT Lightpipe Input jack accepts eight channels of digital audio data at any sample rate between 40KHz and 52KHz. This data is directed thru the eight internal D/A converters to the eight rear balanced audio outputs. The front panel Sample Rate switch **DOES NOT** affect this input. Since the D/A converters sample rate is derived from whatever is coming in the ADAT Input jack, this section can lock to non-standard sample rates as long as they are between 40KHz and 52KHz.

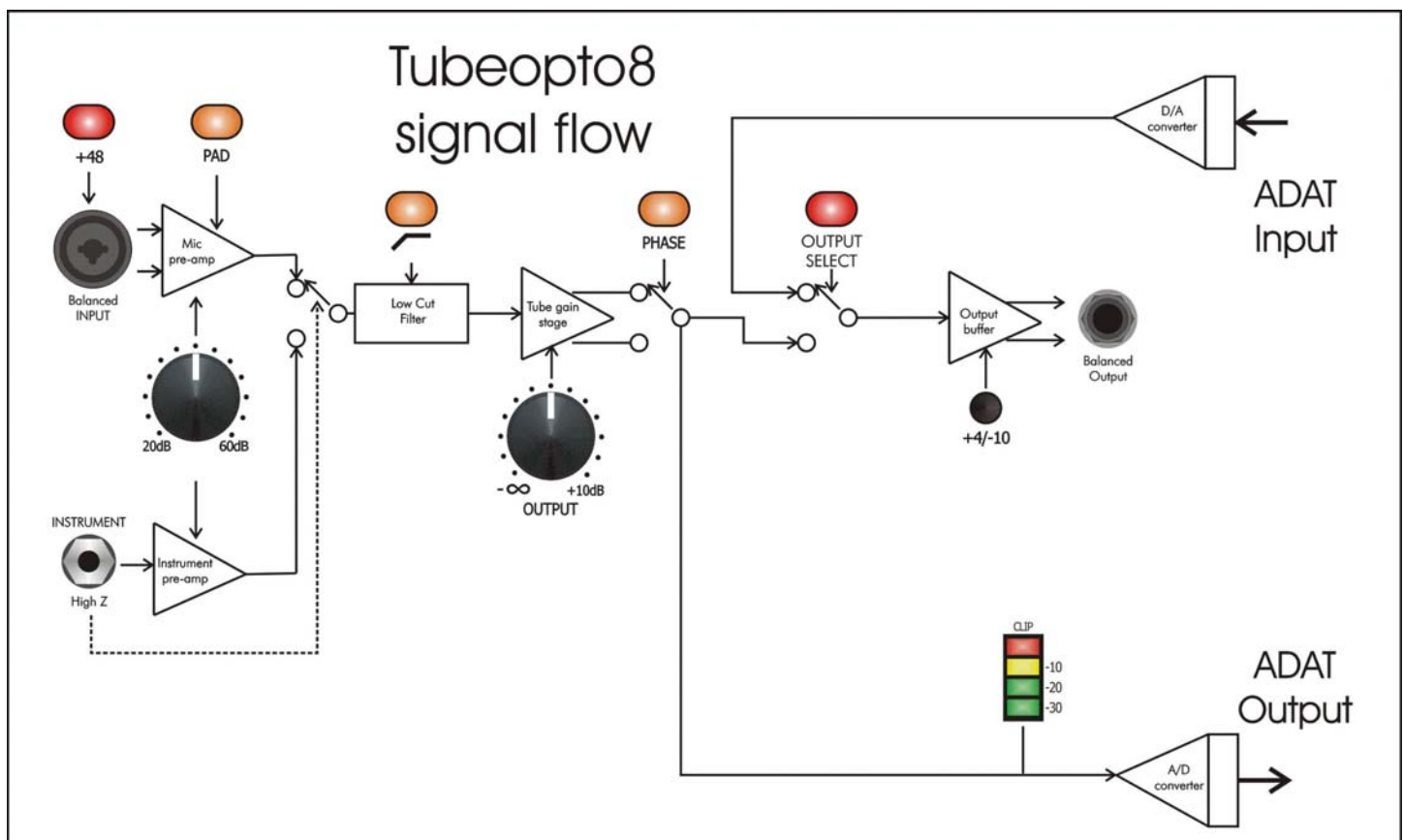

FIGURE 4 - Block Diagram



# HARDWARE OPERATION

## How to adjust the preamplifier controls for the lowest noise

Start with the Gain and Output knobs centered, and the Pad switch in. This provides about 20dB of gain.

Increase the Gain control until the Clip LED in the meter just barely comes on during the loudest peaks in level, and then back off the control slightly from that point. (The Clip LED should come on occasionally at most.)

If there is not enough level with the Gain control set fully clockwise, back off the gain to 12 o'clock and place the Pad switch in the out position. Adjust the Gain control as above.

Adjust the Output control until the -10 LED is on most of the time during loud passages.

Increasing the input Gain control and decreasing the Output level control adds more tube warmth.

Remember, that the Clip LED looks at both the preamp input and output peaks, whereas the -10, -20, -30 LED indicators only look at the preamp output level which feeds the A/D converter.

## How to set the Output Level switch (on the rear panel)

Setting this switch correctly can lower the noise in the output signal chain by optimizing the operating levels between the Tubeopto 8™ and external gear.

One way to determine how this switch should be set is to send audio to the Tubeopto 8™ from an ADAT digital interface and run the audio outputs into a line input on a mixer or signal processor. Check the meters on the mixer or signal processor to see if the level appears to be too high (clipping) or too low (barely showing any indication on the meters). Set the Output Level switch so that the level meters in the external gear do not indicate excessive clipping yet still provide good full-scale (or near full scale) deflection.

## Changing the sample rate

The D/A converters always sync to the incoming ADAT data stream. The front panel display and switch apply to the A/D converter sample rate and sync source. Pushing the Sample Rate switch (or holding it down) cycles through the various settings.

The settings marked **44K** and **48K** select the internal crystal based clock generator. Selecting the internal clock generator makes the Tubeopto 8™ the timing master for your digital system. In this case you would set the rest of your system and software to sync to the Tubeopto 8™. When 48K mode is selected, both Green LEDs are lit to make it easier to read at a distance.

The ADAT sync setting selects the incoming ADAT data stream as the timing source for the Tubeopto 8™. In this case the Tubeopto 8™ would be the slave in terms of timing.

Note: If the signal at the ADAT input jack is not present or has errors, the ADAT LED will flash. This is independent of the sample rate selected.

The Wordclock selection synchronizes the A/D with the signal present at either of the BNC jacks. This is the mode that should be used when you want to have an external Wordclock generator set the master system timing, allowing for multiple devices. This LED will flash if Wordclock mode is selected AND the incoming clock signal is not present or out of lock range.

## Using the Wordclock input

The Tubeopto 8™ can be used in both simple and complex systems. The simplest system would consist of the Tubeopto 8™ and a single ADAT interface. As multiple digital devices are added to a system, master/slave sample rate timing issues can degrade system audio performance. Using a single master Wordclock to synchronize all of the digital processing units reduces timing offset, and eliminates effects from any time drift between the units thereby improving audio quality and reliability. When Wordclock is used it should be applied to EVERY unit in the digital audio chain including soundcards.

First, assure that the Tubeopto 8™ is connected to a good Wordclock generator running at the intended sample rate.

Multiple Tubeopto 8™ units can be daisy-chained by looping the Wordclock signal from unit to unit using the Wordclock Input and Thru jacks of each Tubeopto 8™. A single 75 Ohm BNC terminator is placed on the Wordclock Thru jack of the last device in the chain (furthest away from the Wordclock generator).

Alternatively multiple Tubeopto 8™ units can be connected directly to the separate outputs of a Wordclock generator. In this case each Tubeopto 8™ will require a 75-Ohm BNC terminator placed on its respective Wordclock Thru jack because the Tubeopto 8™ does not internally terminate Wordclock.

Next, click the Sample Rate button until the display shows “Wordclock”.

If the red Wordclock LED is on solid the Tubeopto 8™ is locked to Wordclock. If the red Wordclock LED is flashing, the Tubeopto 8™ is not syncing to Wordclock. Check to make sure that the cables are connected and terminated correctly and the incoming Wordclock signal is between 40KHz and 52KHz.

The Tubeopto 8™ is now slaved to the external Wordclock generator along with the other units in the system.

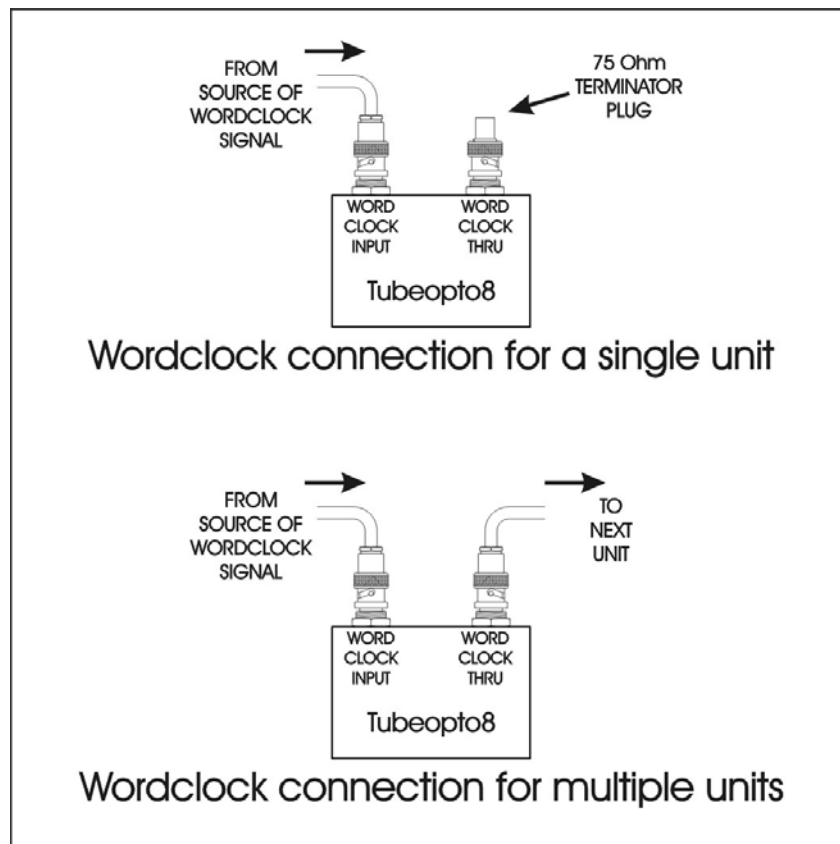

FIGURE 5 - Wordclock Connections

# APPLICATIONS

## Typical applications

The Tubeopto 8™ makes an ideal addition to any ADAT compatible Digidesign interface running ProTools software. Simply connect the ADAT Output from the Tubeopto 8™ to the Optical In of the Digidesign product and connect a 75 Ohm BNC cable between the Digidesign Wordclock Out and the Wordclock In on the Tubeopto 8™. Set the Tubeopto 8™ for Wordclock sync and you have just added 8 more high quality preamp channels to your ProTools setup. If you want to also use the 8 D/A outputs on the Tubeopto 8™ to expand your systems output monitoring capability, simply connect the Optical Out from the Digidesign system to the ADAT Input on the Tubeopto 8™.

If you are using a Digidesign interface that does not have Wordclock output then you can use the Tubeopto 8™ in ADAT sync mode and connect both ADAT Input and Output on the Tubeopto 8™ to Optical Out and In on the Digidesign unit. Set the Digidesign unit to be the sync clock with Optical Out and In being set to ADAT. This would be the preferred method. Alternatively, set the Tubeopto 8™ as master and set it's sample rate to 44.1KHz or 48KHz and connect the ADAT Output on the Tubeopto 8™ to the Optical In on the Digidesign unit. In this case you will need to set the ADAT Optical In to be the "clock" within ProTools.

Other ADAT Lightpipe compatible hardware and DAW applications like Cubase, Sonar, Logic, etc. can benefit in a similar manner to the above. Just make sure you know which unit is acting as the Master Clock and set the other units and software appropriately.

Using Wordclock as your timing master in a system allows multiple Tubeopto 8's to be used to build as many input channels as needed as long as you have sufficient ADAT Lightpipe Inputs. In this application you would connect the Wordclock master to each unit and connect the multiple ADAT Lightpipe Outputs to your multi-ADAT input interface. Each Lightpipe cable would carry 8 channels of ADAT and they would all be synced via Wordclock.

The Tubeopto 8™ can be used as an analog preamp by simply depressing the Output Select switches. Each switch routes pairs of analog input channels to the balanced output jacks.

# Troubleshooting

Here is a list of things to check first:

- 1) Check the power switch. It should be lit red (when the switch is depressed of course). *If not lit red, check the power connections and fuse on the rear panel.*
- 2) Check the Sample Rate lights. There should always be at least one lit. On power up, they first ALL light then light one at a time from 44K to Wordclock and finally settle to the current sample rate. *If the unit does not go through this sequence in the first 5 seconds of power up, there is a problem with the digital section.*
- 3) If you are getting distorted audio, check to make sure that there are NO red LEDs lit on each channel's meter. (The clip indicators work even if the output controls are set to minimum). Listen to the preamp audio by depressing the corresponding channel's Output Select switch. Reduce the input Gain control first to eliminate clipping.
- 4) If the yellow LED is flashing under any sample rate settings, the D/A outputs are muted because there is no valid ADAT data on the unit's ADAT input jack.
- 5) If ADAT sync is selected, the A/D and D/A are muted if the yellow LED is flashing. Apply valid ADAT data to the ADAT Input to correct this.
- 6) If the Wordclock LED is flashing, the unit cannot sync to the Wordclock signal applied to the unit. Check the connection and termination to the Wordclock jacks on the rear of the unit. Make sure that the incoming sample rate is between 40KHz and 52KHz. Use an Internal sample rate (44.1KHz or 48KHz) or sync to ADAT if Wordclock is not available.
- 7) When using the Tubeopto 8™ as a Preamp-to-ADAT only, if the red Wordclock LED is on solid or either of the green (44.1KHz or 48KHz) LED's are on then the Preamp, A/D, and ADAT Output sections will be functioning normally. In this case if the yellow ADAT LED is flashing it just means that you are not using the ADAT Input section.

# **WARRANTY INFORMATION**

## **Limited Warranty:**

Applied Research and Technology will provide warranty and service for this unit in accordance with the following warrants:

Applied Research and Technology, (A R T) warrants to the original purchaser that this product and the components thereof will be free from defects in workmanship and materials for a period of three years from the date of purchase. Applied Research and Technology will, without charge, repair or replace, at its option, defective product or component parts upon prepaid delivery to the factory service department or authorized service center, accompanied by proof of purchase date in the form of a valid sales receipt.

## **Exclusions:**

This warranty does not apply in the event of misuse or abuse of the product or as a result of unauthorized alterations or repairs. This warranty is void if the serial number is altered, defaced, or removed.

A R T reserves the right to make changes in design or make additions to or improvements upon this product without any obligation to install the same on products previously manufactured.

A R T shall not be liable for any consequential damages, including without limitation damages resulting from loss of use. Some states do not allow limitations of incidental or consequential damages, so the above limitation or exclusion may not apply to you. This warranty gives you specific rights and you may have other rights, which vary, from state to state.

For units purchased outside the United States, an authorized distributor of Applied Research and Technology will provide service.

# **SERVICE**

The following information is provided in the unlikely event that your unit requires service.

- 1) Be sure that the unit is the cause of the problem. Check to make sure the unit has power, all cables are connected correctly, and the cables themselves are in working condition. You may want to consult with your dealer for assistance in troubleshooting or testing your particular configuration.
- 2) If you believe the ART unit is at fault, go to [www.artproaudio.com](http://www.artproaudio.com). You may contact Customer Service for more assistance, or directly request a Return Authorization for service in the “resources” area of the website.
- 3) If you are returning the unit for service, pack the unit in its original carton or a reasonable substitute. The original packaging may not be suitable as a shipping carton, so consider putting the packaged unit in another box for shipping. Print the RA number clearly on the outside of the shipping box.
- 4) Include, with your unit, a note with the RA number and your contact information including a daytime phone number, preferably attached to the top of the unit.

Fill in the following information for your reference:

Date of purchase \_\_\_\_\_

Purchased from \_\_\_\_\_

Serial number \_\_\_\_\_

# Tubeopto 8™ SPECIFICATIONS

## Input Impedance

Mic..... 6.4K Ohm  
Line ..... 20K Ohm  
Instrument ..... 2.5M Ohm

## Output Impedance

Balanced outputs..... 200 Ohm balanced

## Frequency Response

Analog in to Digital out ..... 12Hz - 20KHz +0, -1dB @ 44.1 KHz sample rate

## THD

1KHz ..... ≤ .015% @ -30dB ref clipping  
20-20KHz ..... ≤ .033%

**HPF** ..... 80Hz, 1-pole

## Equivalent Input Noise

Mic/Line ..... -130dBu, input shorted, max gain, "A" wtd.  
Instrument ..... -105dBu, input shorted, max gain, "A" wtd.

## Maximum Input Level

Mic/line ..... +18dBu balanced w/pad  
Instrument ..... +15dBu  
Meter clip light ..... -2dB ref. A/D clip (0dB FS)

## Maximum Gain

Mic..... 64dB  
Instrument ..... 36dB

## Maximum Output level

Balanced ..... +20dBu (+4dBu setting)  
Unbalanced ..... +14dBu (+4dBu setting)  
Output level switch ..... Lowers output by 10dB @ -10dBV setting

**Wordclock Range** ..... 40KHz - 52KHz

**Sample Rate Settings**..... 44.1KHz, 48KHz, ADAT, Wordclock

**A/D Dynamic Range**..... 105dB ("A" wtd.)

**D/A Dynamic Range**..... 105dB ("A" wtd.)

**A/D Latency** ..... 0.667ms(48KHz), 0.725ms(44.1KHz), 32 samples

**D/A Latency** ..... 0.458ms(48KHz), 0.500ms(44.1KHz), 22 samples

**Dimensions** ..... 1.75"H x 19.0"W x 14.4"D (44.5mm x 482.6mm x 365.8mm)

**Weight**..... 13.2 lbs. (6kg)

**Power Requirements**..... USA – 105-125VAC, AC 60Hz, 29Watts typical, Export units configured for country of destination.

**Minimum System Requirements**..... ADAT interface port

Note: 0 dBu = 0.775V RMS, 0dBV = 1V RMS

ART maintains a policy of constant product improvement. ART reserves the right to make changes in design or make additions to or improvements upon this product without any obligation to install the same on products previously manufactured. Therefore, specifications are subject to change without notice.



**[www.artproaudio.com](http://www.artproaudio.com)**  
**E-mail: [support@artproaudio.com](mailto:support@artproaudio.com)**

© 2010 Applied Research & Technology