

USB Phono Plus

Audiophile Computer Interface

Project Series

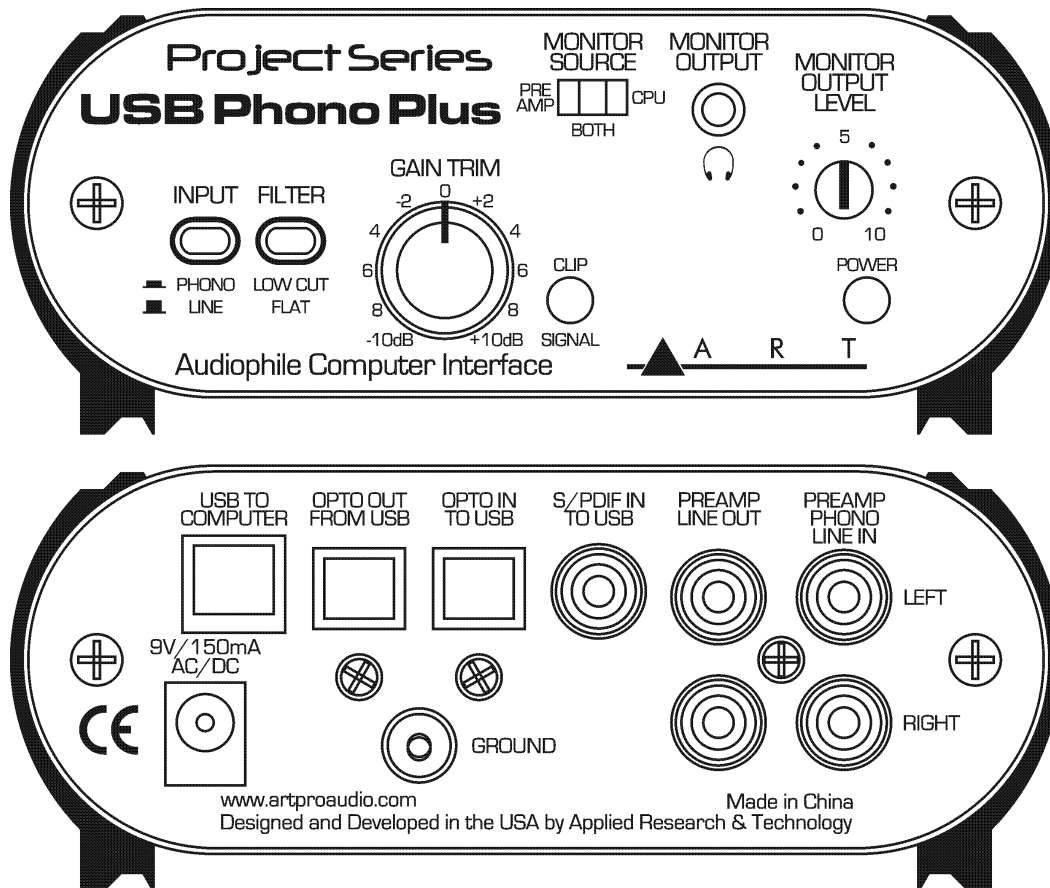

User's Manual



IMPORTANT SAFETY INSTRUCTION – READ FIRST



This symbol, whenever it appears, alerts you to the presence of uninsulated dangerous voltage inside the enclosure-voltage that may be sufficient to constitute a risk of shock.



This symbol, wherever it appears, alerts you to important operating and maintenance instructions in the accompanying literature. Please read the manual.

Read instructions:

Retain these safety and operating instructions for future reference. Heed all warnings printed here and on the equipment. Follow the operating instructions printed in this user manual.

Do not open:

There are no user serviceable parts inside. Refer any service work to qualified technical personnel only.

Moisture:

To reduce the risk of fire or electrical shock do not expose the unit to moisture or use in damp or wet conditions. Do not place container of liquid on unit.

Heat:

Do not locate the unit close to excessive heat or direct sunlight, as this could cause a fire hazard. Locate the unit away from any equipment, which produces heat such as: power supplies, power amplifiers and heaters.

Environment:

Protect from excessive dirt, dust, heat, and vibration when operating and storing. Avoid tobacco ash, drink spillage and smoke, especially that associated with smoke machines.

Handling:

Protect the controls from damage during transit. Use adequate padding if you need to ship the unit. To avoid injury to yourself or damage to the equipment, take care when lifting, moving, or carrying the unit.

Servicing:

Unplug power immediately if equipment is exposed to moisture, the power supply becomes damaged during a lightning storm or if smoke odor or noise is noted. Refer servicing to qualified technical personnel only.

Installation:

Install the unit in accordance with the instructions printed in the user manual.

INTRODUCTION

The **USB Phono Plus Project Series** is a high quality USB audio interface with a built-in phono preamp. It acts as an interface between your computer and a wide variety of analog and digital sources. The analog inputs are switchable between Phono and Line level signals and a Low Cut filter removes rumble and wind noise while leaving the audio pristine. The front Gain Trim control and Signal/Clip LED allow you to optimize the analog to digital converter for a wide range of input sources. The front panel USB Monitor/headphone jack and the Optical Output on the rear panel can monitor the audio output from your computer. The USB Monitor/headphone jack can also provide zero latency monitoring of the input source for easy cueing of records and tapes. The built-in low noise Phono Preamp circuit is highly accurate and precisely conforms to the RIAA standard. The Line Out jacks are always connected to the input preamp signal for source monitoring or to allow use as a stand-alone phono preamp.

Housed in an all aluminum black anodized case, the **USB Phono Plus Project Series** can be powered by either an external power source or directly off the USB port, so remote recording is a snap. An Optical TOSLINK Input and Output as well as an S/PDIF Input let you use the **USB Phono Plus Project Series** as a digital audio to USB interface as well.

The **USB Phono Plus Project Series** is fully compliant with the USB 2.0 specification and uses USB adaptive mode for playback and USB asynchronous mode for recording. The **USB Phono Plus Project Series** interface uses the standard “USB Audio CODEC”. This driver is built into most modern operating systems, including most current versions of Linux. Since some details of how the audio interface is set vary with different versions of Linux, the setup is beyond the scope of this document. The main key in setup is to look for “USB Audio CODEC” as the recording source or playback monitor output while the **USB Phono Plus Project series** is connected. No special drivers are needed. We’ve included a CDROM containing the user manual and Audacity recording software to get you started!

Key Features Include

- USB Connectivity to Desktop and Laptop Computers
- RIAA Accurate Low Noise Phono Preamp
- Up to 45 dB of Clean Gain
- Latency Free Monitoring
- S/PDIF or optical to USB and USB to Optical Interfaces Included
- Preamp Line Out Allows Use as a Stand-alone Phono Preamp
- Includes Audacity Recording Software
- Compact, Stackable all Aluminum Chassis
- Flexible Power from USB Connection, External Power Supply (Optional)
- Three Year Warranty

CONNECTIONS

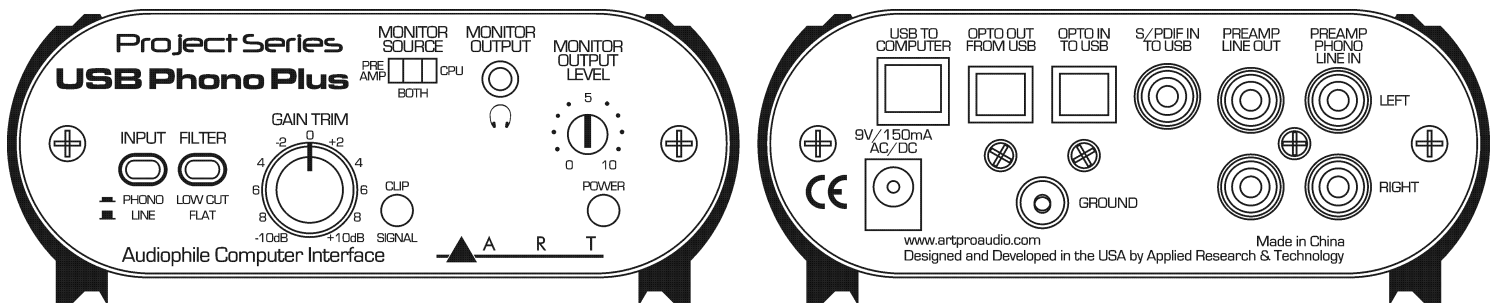

The **Preamp Phono/Line In** connections are RCA-type jacks and are used to connect your turntable, tape, CD, MP3 player, or other analog stereo audio device to the **USB Phono Plus Project Series**.

The **Ground** terminal connection on the rear is used to connect the separate ground wire from your turntable to reduce hum. (This connection is unnecessary for digital output turntables).

The **Preamp Line Out** connections are RCA-type jacks that are always connected to the analog input preamp signal for source monitoring or to allow use as a stand-alone phono preamp.

The **S/PDIF In To USB** RCA-type connection is a digital input that overrides the **Opto In** and analog preamp signal connections whenever there is a valid digital signal present that is in S/PDIF format. This digital signal input is routed to the your computer USB interface for S/PDIF to USB connectivity only. **Note:** You cannot connect S/PDIF to analog or analog to S/PDIF with this product.

The **OPTO In To USB** and **OPTO Out From USB** connections provide for Optical digital connections direct to your computer via USB. When there is valid TOSLINK digital signal at the **OPTO In** connection it overrides the analog preamp signal connection to the USB interface.

NOTE: The optical inputs accept only **NON-copyrighted, consumer** (not professional) **formatted** digital material. The sample rate must be between 32kHz and 48kHz. All material is sent to the computer interface only.

The 1/8-inch Headphone **Monitor Output** jack on the front is stereo unbalanced and can accommodate a wide variety of headphone models. Maximum output level is +6dBu (1.4Vrms).

The USB bus from your computer normally powers the **USB Phono Plus Project Series**. A power connector on the rear allows you to use an **optional external power source** to reduce the power drawn from your computer. The **USB Phono Plus Project Series** operates from any external power source that provides 150mA or more @ 7 Volts to 12 Volts DC (either polarity at the tip will work with our unit) or 9 Volts to 12 Volts AC.

The **USB To Computer** connector is USB 2.0 compliant and should be used to connect directly to one of the USB connections on your computer. This connection also powers the USB circuitry inside the **USB Phono Plus Project Series** and will power the whole product if no other power source is available. This connection looks like a standard “USB Audio CODEC” to your computer, and your computer then controls the sample rate.

Since the USB connection will be carrying high quality digital audio to and from your computer as well as bus powering the USB interface, we suggest that you use a high quality shielded USB cable for best performance. Ideally you should connect directly to one of the USB inputs on your computer. Connecting through a shared hub can reduce power and bandwidth that is available for each USB device and should be avoided when possible. Though the **USB Phono Plus Project Series** is compatible with both USB 1.1 and 2.0 standards, USB 2.0 is preferred for the cabling and computer connection as it allows for more system bandwidth. If you must use a hub, it should be a powered USB 2.0 compliant hub for best results. This is especially important if you plan on using multiple units for more channels of simultaneous digital audio input over USB connections.

CONTROLS

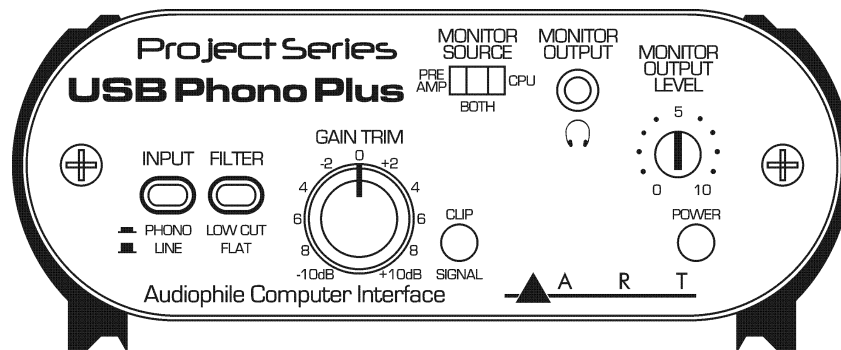

The **Input** switch sets the gain and equalization of the analog preamp. If using a phono turntable, set the switch to **Phono**. Otherwise set the switch to **Line** for other types of audio sources.

The **Filter** switch, when in the **Low Cut** position, adds a filter for removing turntable rumble or other low frequency noise.

The **Gain Trim** control adjusts the overall analog preamp gain. The **Clip/Signal** LED indicator, located to the right of the **Gain Trim** control, lights green when there is signal present and red if the signal level is near clipping. Adjust the **Gain Trim** while noting the **Signal/Clip** LED so that green is on most of the time (with music playing) and red is on rarely during signal peaks. By doing this you optimize the dynamic range of the analog preamp and USB interface.

The **Monitor Source** switch selects what signal is sent to the **Monitor Output Level** control and **Monitor Output** jack. In the **Preamp** position you are directly monitoring the analog preamp signal before it is sent to your computer, for zero latency monitoring and cueing of the audio source. In the **CPU** position you are monitoring the digital audio signal that is coming back from your computer, on playback. The **Both** position provides a mix of the preamp and computer signals.

The **Monitor Output Level** control adjusts the signal level available at the **Monitor Output** jack.

The red **Power** LED indicator lights whenever the **USB Phono Plus Project Series** is being powered either through the USB connection from your computer or via the external power connection on the rear.

INSTALLATION

1. Connect your turntable, tape player, CD player or other analog audio device cables to the RCA input connectors or connect your digital audio device to the S/PDIF or OPTO inputs on the **USB Phono Plus Project Series**.

a. If you are using a turntable and it has a separate ground wire, attach it to the ground terminal on the **USB Phono Plus Project Series**. This will help to reduce hum.

b. Select **LINE** or **PHONO** input for the analog source type. Use the **LOW CUT Filter** for removing turntable rumble or other low frequency noise if you find it is desirable.

2. Connect the **USB Phono Plus Project Series** USB connection to the appropriate USB input on your computer.

3. **USB BUS POWER:** No external power connection is needed. Power is supplied over the USB connection. The front panel **POWER** LED will indicate that USB power is present when the USB cable is connected to a live USB jack. It is best to connect directly to a computer USB input or to a powered USB hub, to ensure ample power for the **USB Phono Plus Project Series**.

NOTE: **EXTERNAL POWER** will automatically override **USB BUS POWER**. This can be useful for reducing power drain when connecting to battery powered laptop computers.

MONITORING WHAT YOU RECORD

Set the front **MONITOR SOURCE** switch to **PREAMP** in order to monitor the analog audio coming directly from the preamp. This is useful for auditioning and cueing records or tapes prior to recording. This signal has no delay or latency.

Set the front **MONITOR SOURCE** switch to **CPU** in order to monitor the digital audio coming back from the computer. This is useful for playback from the computer and software configuration. See discussion below.

A third position on the **MONITOR SOURCE** switch is labeled **BOTH** and it provides a mix of the preamp and computer signals. During typical operation either a record (or tape) is playing back, or the computer is playing back, but not both at the same time. You can listen to either the preamp, or the computer, without changing any settings. You will also be able to hear any computer alert signals while you are listening to the record or tape if the alerts are also routed to the USB CODEC in your computer's sound setting control panel.

Some recording programs and computer systems provide what is called a "Play-Through" function. This can be performed through software or hardware. When Play-Through is set to ON, the computer will output the audio that is being recorded, at the same time that it is actually being recorded. There is a short delay, or latency, with this audio signal. There is also a potential for the computer's audio inputs and outputs to be inadvertently connected together thereby forming a feedback loop. This can accidentally create very loud and disturbing sounds. Therefore Play-Through is usually set to OFF as the default setting in both software and hardware.

If Software/Hardware Play-Through is set to ON and the **MONITOR SOURCE** switch is in the **BOTH** position, then you will most likely hear the original preamp signal together with the computer audio

signal slightly delayed, thereby creating an echo effect. This is normal behavior, so while using the **BOTH** setting it may be preferable to leave the Play-Through set to OFF.

OPERATION WITH A COMPUTER

Once the USB connection is made and your computer is on, your computer will power the USB interfaces circuitry over the USB bus and the unit will automatically connect and try to set your computer “Default Audio Device” to be “USB Audio CODEC”. Usually the computer will do this automatically whenever a USB device is first connected, but it is sometimes necessary to make the selection manually. The same settings may need to be made in your particular audio application as well (Check your application instructions). These settings should be made while the USBPhonoPlusPS and computer are connected and powered on.

Your computer audio output “Speaker” is now set to be the “USB Audio CODEC” and playback audio is routed to the USB Mix. This must be done while the USB Mix is connected to the computer and powered on. If you prefer, you can have the computer output routed to your computer speakers instead of the USBPhonoPlusPS monitor output jack, by selecting your computer speakers for “OUTPUT” instead of “USB Audio CODEC” in the above setup procedures. After the above settings are made, your computer will automatically reconfigure itself back to these settings every time the USB Mix is reconnected to the computer. Your recording software may also select which inputs or outputs are being used.

NOTE: The USB Phono Plus **Project Series** interface uses the standard “USB Audio CODEC”. This driver is built into most modern operating systems, including most current versions of Linux. Since some details of how the audio interface is set vary with different versions of Linux, the setup is beyond the scope of this document. The main key in setup is to look for “USB Audio CODEC” as the recording source or playback monitor output while the USBPhonoPlusPS is connected.

USB Phono Plus Project Series FAQ

1. **The digital input does not work (Optical jack or RCA).**
 - a. The optical inputs accept only NON-copyrighted, consumer (not professional) formatted digital material. The sample rate must be between 32kHz and 48kHz.
2. **The unit does not send the optical or S/Pdif audio to any output jack.**
 - a. The Block diagram shows the signal path for the Digital inputs is only passed to the computer through the USB interface.

BLOCK DIAGRAM AND SIGNAL FLOW

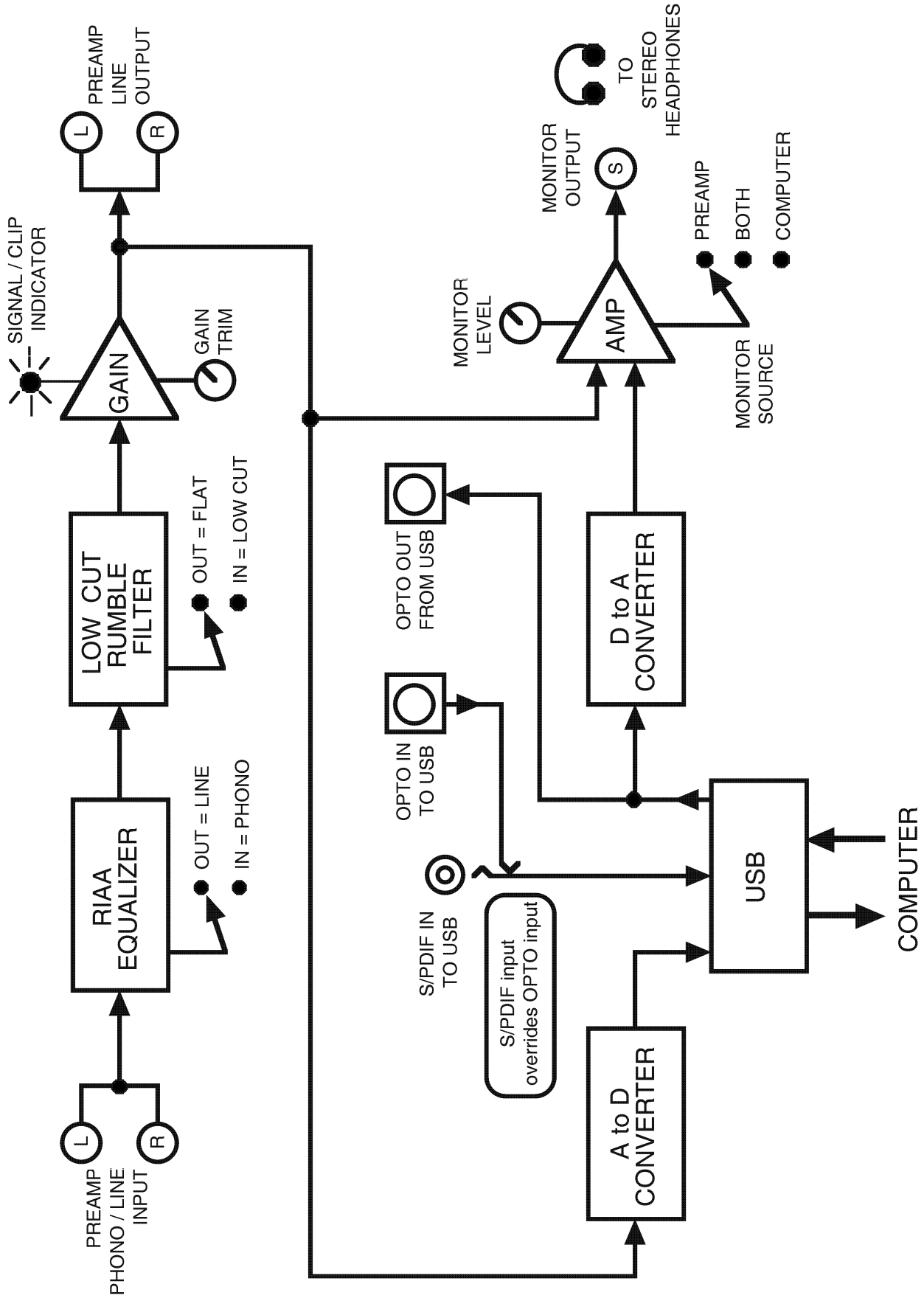

WARRANTY INFORMATION

Limited Warranty

Applied Research and Technology will provide warranty and service for this unit in accordance with the following warrants:

Applied Research and Technology, (A R T) warrants to the original purchaser that this product and the components thereof will be free from defects in workmanship and materials for a period of **three** years from the date of purchase. Applied Research and Technology will, without charge, repair or replace, at its option, defective product or component parts upon prepaid delivery to the factory service department or authorized service center, accompanied by proof of purchase date in the form of a valid sales receipt.

Online Registration

We recommend that you register your product online to insure prompt warranty repair servicing on any repair issues. Please go to www.artproaudio.com. Select "*Support*", then "*Product Registration*". Then input your information here.

Exclusions

This warranty does not apply in the event of misuse or abuse of the product or as a result of unauthorized alterations or repairs. This warranty is void if the serial number is altered, defaced, or removed.

A R T reserves the right to make changes in design or make additions to or improvements upon this product without any obligation to install the same on products previously manufactured.

A R T shall not be liable for any consequential damages, including without limitation damages resulting from loss of use. Some states do not allow limitations of incidental or consequential damages, so the above limitation or exclusion may not apply to you. This warranty gives you specific rights and you may have other rights, which vary from state to state.

For units purchased outside the United States, an authorized distributor of Applied Research and Technology will provide service

SERVICE

The following information is provided in the unlikely event that your unit requires service.

1. Be sure that the unit is the cause of the problem. Check to make sure the unit has power, all cables are connected correctly, and the cables themselves are in working condition. You may want to consult with your dealer for assistance in troubleshooting or testing your particular configuration.
2. If you believe that the ART unit is at fault, go to www.artproaudio.com.
3. Select “*Support*”, then “*Return Authorization Request*” to request a return authorization number.
4. If you are returning the unit for service, pack the unit in its original carton or a reasonable substitute. The original packaging may not be suitable as a shipping carton, so consider putting the packaged unit in another box for shipping. Print the RA number clearly on the outside of the shipping box. Print your return shipping address on the outside of the box.
5. Include, with your unit, a note with the RA number and your contact information, including a return shipping address (we cannot ship to a P.O. box) and a daytime phone number, and a description of the problem, preferably attached to the top of the unit. Also include a copy of your purchase receipt.

Fill in the following information for your reference:

Date of purchase _____

Purchased from _____

SPECIFICATIONS

Frequency Response	10 Hz – 50 kHz, +/- 0.5%
THD	<0.01% typical @ 1 kHz
Hum and Noise	>90 dB below clipping
Input Impedance	47k Ohms/100pf (phono), 270k Ohms (line)
Maximum Input Level	40 mV rms @ 1 kHz (phono), +19dBu (line)
Maximum Gain	45dB @ 1 kHz (phono), 6dB (line)
Analog Input Connections	RCA (preamp / phono/line output)
Analog Output Connection	RCA (preamp line output) 1/8-inch (monitor/headphone output)
Maximum Output Level	+6dBu (1.4V rms)
Filter Type / Response	Switchable, high pass (low cut) –3dB @ 22 Hz
A/D-D/A	16 bit, 44.1 kHz or 48 kHz, USB selectable from computer 0.4 ms A/D latency @ 44.1 kHz
Digital Audio Interface	TOSLINK Opto In to USB, TOSLINK Opto Out from USB, S/PDIF coax (RCA) In to USB
Computer Interface	USB Class compliant plug-and-play Mac and PC interface
Chassis Type	All aluminum black anodized with integral rubber sides
Power Requirements	USB bus powered or Optional 7-12V DC or 9-12V AC @ 150mA (external) Either polarity of the tip will work with DC power
Dimensions(HWD)	1.85-inch x 4.6-inch x 4.5-inch 47mm x 117mm x 114mm
Weight	1.35 lbs, 0.61 kg

Note: 0 dBu = 0.775Vrms

ART maintains a policy of constant product improvement.
Therefore, specifications are subject to change without notice.

Go to www.artproaudio.com for the latest information and on the **USB Phono Plus Project Series**



www.artproaudio.com
E-mail: support@artproaudio.com

© 2019 Applied Research & Technology / Yorkville Sound