

# ART S83WAY

Eight Channel Three-Way High Performance Microphone Splitter

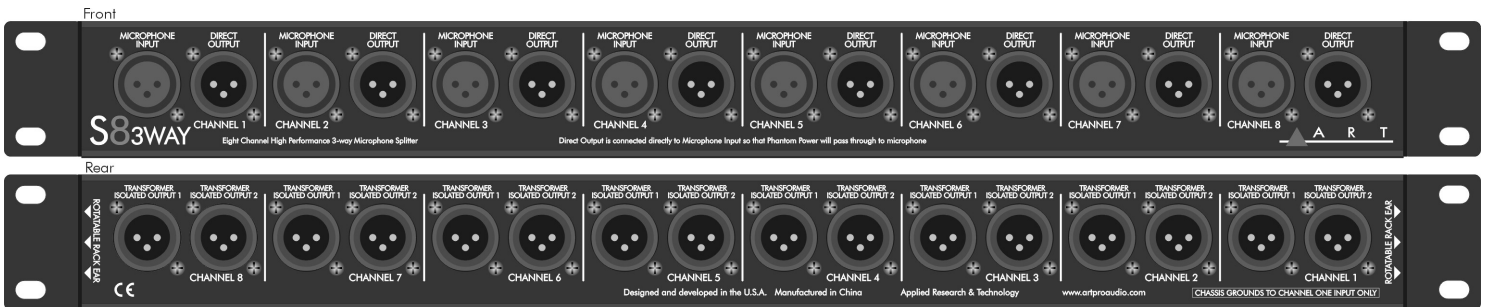

## USER'S MANUAL



# IMPORTANT SAFETY INSTRUCTIONS - READ FIRST



This symbol, wherever it appears, alerts you to the presence of uninsulated dangerous voltages inside the enclosure that may be sufficient to constitute a risk of shock.



This symbol, wherever it appears, alerts you to important operating and maintenance instructions in the accompanying literature. Please read the manual.

## **Read instructions**

Retain these safety and operating instructions for future reference. Heed all warnings printed here and on the equipment. Follow the operating instructions printed in this user guide.

## **Do not open**

There are no user serviceable parts inside. Refer any service work to qualified technical personnel only.

## **Moisture**

To reduce the risk of fire or electrical shock, do not expose the unit to rain, moisture or use in damp or wet conditions. Do not place container of liquid on it, which may spill into any openings

## **Heat**

Do not locate the unit in a place close to excessive heat or direct sunlight, as this could be a fire hazard. Locate the unit away from any equipment, which produces heat such as: power supplies, power amplifiers and heaters.

## **Environment**

Protect from excessive dirt, dust, heat, and vibration when operating and storing. Avoid tobacco ash, drink spillage and smoke especially that associated with smoke machines.

## **Handling**

Protect the controls from damage during transit. Use adequate padding if you need to ship the unit. To avoid injury to yourself or damage to the equipment take care when lifting, moving or carrying the unit.

## **Servicing**

Disconnect immediately if it is exposed to moisture, spilled liquid. Refer servicing to qualified technical personnel only.

## **Installation**

Install the unit in accordance with the instruction printed in the user manual.

## INTRODUCTION

S8-3WAY eight channel three way microphone splitter is ideal for live sound, fixed install, recording, and broadcast applications where microphone and XLR balanced line level input signals have to go to multiple mix locations.

Each channel provides one XLR input, one XLR direct output, with two additional transformer isolated XLR outputs for a total of 3 balanced outputs from each microphone input signal.

Typical uses would include sending 8 direct signals through the S8-3WAY to a main or FOH (Front Of House) mixer, with additional isolated feeds going to a monitor mix station, remote recording desk, or broadcast feed. The direct outputs pass phantom power from the main mixer to the microphones for use with condenser microphones.

### Features

- The same high quality musical sounding transformer design used in the popular ART S8
- XLR input, one XLR direct output, with two additional transformer isolated XLR outputs
- High quality passive interface
- 19-inch 1U-high rack mount with rugged, fully shielded black all-steel enclosure
- Reversible rack ears for added system flexibility
- Three year warranty

## USING THE MICROPHONE SPLITTER

Connect low impedance dynamic or condenser microphone to any MICROPHONE INPUT on the S8-3WAY.

Connect corresponding DIRECT MICROPHONE OUTPUT to mic input on main mixer (switch phantom power on at mixer if desired).

Connect corresponding TRANSFORMER ISOLATED MICROPHONE OUTPUT 1 to mic input on secondary mixer or recording system.

Connect corresponding TRANSFORMER ISOLATED MICROPHONE OUTPUT 2 to mic input on third mixer or recording system.

**NOTE:** The chassis ground connects to the Channel One input ground only, in order to reduce the possibility of channel crosstalk through chassis ground. To provide the noise-shielding benefit of the chassis enclosure when the S8 is not mounted in a grounded rack system, be sure to use the Channel One input when using fewer than eight channel input connections.

Front

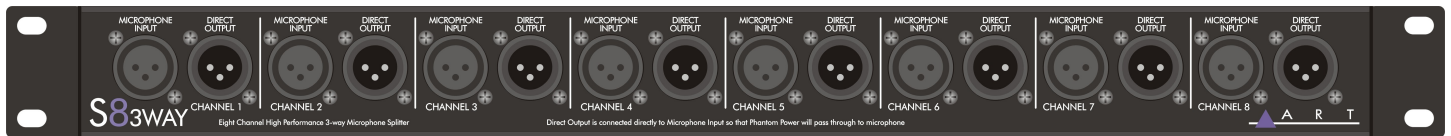

Rear

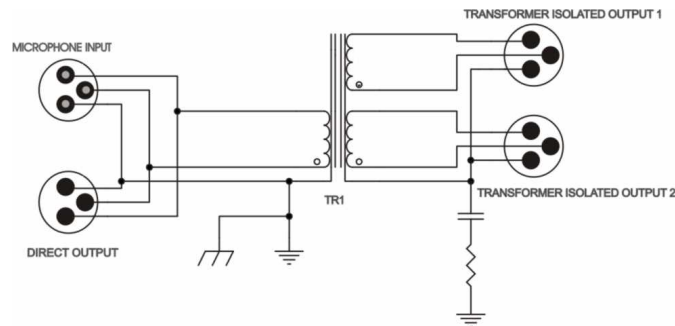
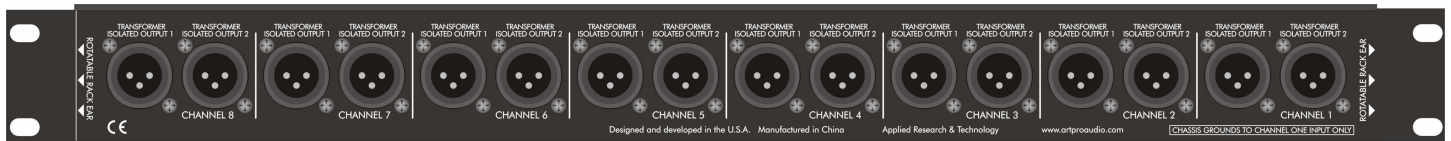

Signal Flow Chart

# WARRANTY INFORMATION

## Limited Warranty

Applied Research and Technology will provide warranty and service for this unit in accordance with the following warrants:

Applied Research and Technology (A R T) warrants to the original purchaser that this product and the components thereof will be free from defects in workmanship and materials for a period of **three** years from the date of purchase. Applied Research and Technology will, without charge, repair or replace, at its option, defective product or component parts upon prepaid delivery to the factory service department or authorized service center, accompanied by proof of purchase date in the form of a valid sales receipt.

## Online Registration

We recommend that you register your product online to insure prompt warranty repair servicing on any repair issues. Please go to [www.artproaudio.com](http://www.artproaudio.com). Select "*Support*", then "*Product Registration*". Then input your information here.

## Exclusions

This warranty does not apply in the event of misuse or abuse of the product or as a result of unauthorized alterations or repairs. This warranty is void if the serial number is altered, defaced, or removed.

**ART** reserves the right to make changes in design or make additions to or improvements upon this product without any obligation to install the same on products previously manufactured.

**ART** shall not be liable for any consequential damages, including without limitation damages resulting from loss of use. Some states do not allow limitations of incidental or consequential damages, so the above limitation or exclusion may not apply to you. This warranty gives you specific rights and you may have other rights, which vary from state to state.

For units purchased outside the United States, an authorized distributor of Applied Research and Technology will provide service.

## SERVICE

The following information is provided in the unlikely event that your unit requires service.

1. Be sure that the unit is the cause of the problem. Check to make sure the unit has power, all cables are connected correctly, and the cables themselves are in working condition. You may want to consult with your dealer for assistance in troubleshooting or testing your particular configuration.
2. If you believe that the ART unit is at fault, go to [www.artproaudio.com](http://www.artproaudio.com).
3. Select "*Support*", then "*Return Authorization Request*" to request a return authorization number.
4. If you are returning the unit for service, pack the unit in its original carton or a reasonable substitute. The original packaging may not be suitable as a shipping carton, so consider putting the packaged unit in another box for shipping. Print the RA number clearly on the outside of the shipping box. Print your return shipping address on the outside of the box.
5. Include, with your unit, a note with the RA number and your contact information, including a return shipping address (we cannot ship to a P.O. box) and a daytime phone number, and a description of the problem, preferably attached to the top of the unit. Also include a copy of your purchase receipt.

**Please fill in the following information for your reference:**

Date of purchase \_\_\_\_\_

Purchased from \_\_\_\_\_

Serial Number \_\_\_\_\_

## SPECIFICATIONS

FREQUENCY RESPONSE	20 Hz to 20K Hz, $\pm 0.25$ dB @ -15 dBu, -3 dB at approximately 165K Hz
THD + NOISE	Less than 0.26% from 20 Hz to 20K Hz at -15 dBu input Less than 0.1% from 45 Hz to 20K Hz at -15 dBu input 0.002% Typical at 1K Hz, -15 dBu input
PHASE RESPONSE	Less than 10 degrees at 20K Hz (ref. 1K Hz)
INPUT IMPEDANCE	Greater than 1.1K Ohms at 1K Hz (Typical driving source impedance is 150 Ohms)
OUTPUT IMPEDANCE	Less than 255 Ohms at 1K Hz (Typical output load impedance is 1K Ohms)
CMRR	Greater than 105 dB @ 60 Hz, Greater than 80 dB @ 3K Hz
VOLTAGE INSERTION LOSS	Approximately 2 dB at 1K Hz
MAX INPUT LEVEL FOR 1% THD	-1.4 dBu at 20 Hz, +3.5 dBu at 30 Hz, +9.4 dBu at 50 Hz
DIMENSIONS (HWD)	1.75-inch x 19-inch x 3.75-inch 44.5mm x 482.6mm x 95mm
WEIGHT	3.75 lbs. (1.7 kg)

Ref: 0 dBu = 0.775 VRMS

**NOTE:** All measurements made from TRANSFORMER ISOLATED MICROPHONE OUTPUT with 150 Ohm balanced source feeding MICROPHONE INPUT and 1K Ohm load connected to TRANSFORMER ISOLATED MICROPHONE OUTPUT to simulate a typical “real world” microphone and mic preamplifier.



**[www.artproaudio.com](http://www.artproaudio.com)**  
**E-mail: [support@artproaudio.com](mailto:support@artproaudio.com)**

© 2019 Applied Research & Technology