

# *CLEAN***Box***Pro*

*Two Channel Pro/Consumer Level Converter*

## Artcessories



## User's Manual



## IMPORTANT SAFETY INSTRUCTION – READ FIRST



This symbol, whenever it appears, alerts you to the presence of uninsulated dangerous voltage inside enclosure-voltage that may be sufficient to constitute risk of shock.



This symbol, whenever it appears, alerts you to important operating and maintenance instructions in the accompanying literature. Please read the manual.

**Read Instructions:** Retain safety and operating instructions for future reference. Heed all warnings printed here and on the equipment. Follow the operating instructions printed in this user guide.

**Do not open:** There are no user serviceable parts inside. Refer any service work to qualified technical personnel only.

**Grounding:** Only connect the unit to equipment with properly grounded mains power. Do not defeat the grounding and polarization means of the power cord plug of the connected equipment. Do not remove or tamper with the ground connection on the power cord of the connected equipment.

**Environment:** Protect from excessive dirt, dust, heat, and vibration when operating and storing. Avoid tobacco ash, drink spillage and smoke, especially that associated with smoke machines.

**Handling:** Protect the controls from damage during transit. Use adequate padding if you need to ship the unit. To avoid injury to yourself or damage to the equipment, take care when lifting, moving or carrying the unit.

**Servicing:** Refer servicing to qualified technical personnel.

**Installation:** Install the unit in accordance with the instructions printed in the user guide.

## **INTRODUCTION:**

Thanks for purchasing Applied Research and Technology's CLEANBoxPro. The CLEANBoxPro provides two channels of unbalanced to balanced level conversion and two channels of balanced to unbalanced level conversion in a rugged, compact, and portable unit. Balanced lines offer increased immunity to external electrical noise, such as hum. Since a balanced system minimizes induced noise, it is the preferred method of connecting audio gear, especially when long lengths of cable are used.

One section of the CLEANBoxPro converts two channels of consumer-level unbalanced input signals into two channels of pro line-level balanced output signals. It has two RCA jack inputs and a stereo mini-phone jack input connected in parallel. The balanced output feeds two XLR male jacks.

The other section of the CLEANBoxPro converts two channels of line-level balanced input signals into two channels of consumer unbalanced output signals. It has two XLR female input jacks. The unbalanced output feeds two RCA jacks and a stereo mini-phone jack connected in parallel.

Each section has stereo level controls to optimize signal levels. An LED indicator lights when power is applied.

The CLEANBoxPro can be an invaluable tool in application areas including (but not limited to!): home or professional recording studios, live sound, PA, permanent installs, DJ, AV, consumer HiFi, podcasting

and broadcasting. The CLEANBoxPro can be used with: mixers, audio processors, laptop computers, computer sound cards, CD/DVD players, video gaming machines, MP3 player/recorders, powered monitors and digital audio workstations.

## **FEATURES:**

- XLR connectors for balanced inputs and outputs
- RCA phono jacks and stereo 1/8-inch mini-phone jacks for unbalanced inputs and outputs
- Stereo unbalanced output level control
- Stereo balanced output level control
- Rugged extruded aluminum case
- Lighted On/Off switch
- Comes with an external power supply for operation with AC mains
- Low noise, low distortion circuit

## **INSTALLATION and OPERATION:**

### **Unbalanced-to-Balanced: RCA / mini-phone to XLR**

1. Connect the left and right stereo outputs of the consumer audio unit (CD/DVD player, MP3 player, computer sound card, etc.) to the CLEANBoxPro's **-10dBV UNBALANCED INPUT 1 & 2** RCA connectors or to the **-10 dBV UNBAL INPUT 1/8"** phone jack, using the appropriate cable.
2. Connect the CLEANBoxPro's **+4dBu BALANCED OUTPUT 1 & 2** male XLR connectors to the balanced inputs of the pro audio unit (e.g. a power amplifier or two channels of a mixer) with two low-impedance balanced XLR cables.
3. With power applied, adjust the **BALANCED OUTPUT LEVEL** control as required for best signal strength and clarity.

### **Balanced-to-Unbalanced: XLR to RCA / mini-phone**

1. Connect the left and right balanced outputs from your pro audio unit (e.g. mixer or processor) to the CLEANBoxPro's **+4dBu BALANCED IN 1 & 2** female XLR connectors with two low-impedance balanced XLR cables.
2. Connect the CLEANBoxPro's **-10dBV UNBALANCED OUTPUT 1 & 2** RCA connectors or **-10 dBV UNBAL OUTPUT 1/8"** phone jack to the left and right inputs on your consumer audio unit (computer sound card, digital recorder, stereo sound system, etc.) with the appropriate cable.

3. With power applied, adjust the **UNBALANCED OUTPUT LEVEL** control for best signal strength and clarity.

### Inline Balanced or Unbalanced Level/Gain Control

1. Loop **unbalanced outputs** to **unbalanced inputs** to provide an inline **balanced** level / gain control.

2. Loop **balanced outputs** to **balanced inputs** to provide an inline **unbalanced** level / gain control.

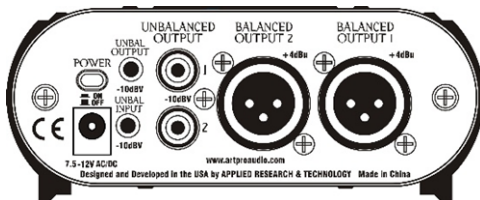

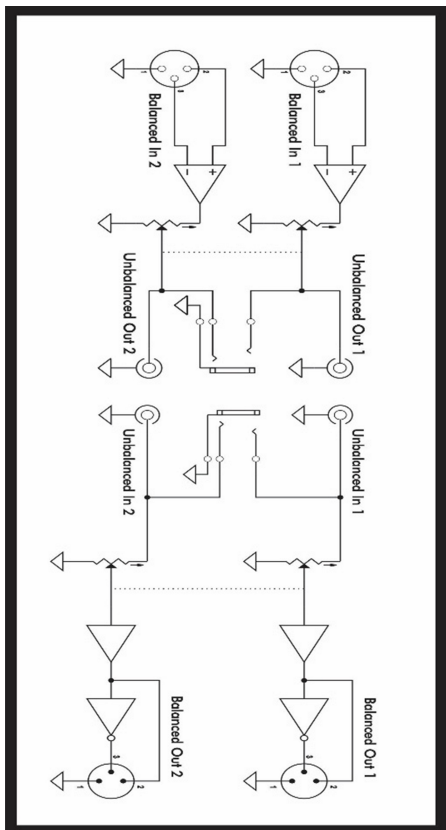

**Signal Flow Chart**

## **SPECIFICATIONS:**

<b>Frequency Response :</b>	20 Hz – 20 kHz, $\pm$ 1 dB
<b>THD :</b>	< .01% @ 1 kHz
<b>Signal to Noise Ratio :</b>	> 90 dB
<b>CMRR :</b>	> 40 dB
<b>Input Impedance:</b>	balanced - 20k Ohms unbalanced -100k Ohms
<b>Output Impedance :</b>	balanced -100 Ohms unbalanced - 300 Ohms
<b>Maximum Gain :</b>	balanced to unbalanced -6 dB, unbalanced to balanced +21 dB
<b>Maximum Input Level :</b>	+21 dBu
<b>Maximum Output Level :</b>	balanced +21 dBu unbalanced +15 dBu
<b>Power :</b>	7.5-12 V AC/DC, < 150 mA
<b>Dimensions HxWxD (in) :</b>	1.85 x 4.6 x 4.3
<b>HxWxD(mm) :</b>	47 x 117 x 109
<b>Weight (lbs/kg) :</b>	1.10 / 0.50

## **WARRANTY INFORMATION:**

### **Limited Warranty (USA only)**

Applied Research and Technology will provide warranty and service for this unit in accordance with the following warrants:

Applied Research and Technology, (ART) warrants to the original purchaser that this product and the components thereof will be free from defects in workmanship and materials for a period of **three** years from the date of purchase. Applied Research and Technology will, without charge, repair or replace, at its option, defective product or component parts upon prepaid delivery to the factory service department or authorized service center, accompanied by proof of purchase date in the form of a valid sales receipt.

### **Exclusions**

This warranty does not apply in the event of misuse or abuse of the product or as a result of unauthorized alterations or repairs. This warranty is void if the serial number is altered, defaced, or removed.

ART reserves the right to make changes in design or make additions to or improvements upon this product without any obligation to install the same on products previously manufactured.

ART shall not be liable for any consequential damages, including without limitation damages resulting from loss of use. Some states do not allow limitations of incidental or consequential damages, so the above limitation or exclusion may not apply to you. This warranty gives you specific rights and you may have other rights, which vary,

from state to state. The warranty terms listed above are only valid within the United States of America.

For units purchased outside the United States, an authorized distributor of Applied Research and Technology will provide service. For information on warranty and service policies outside of the U.S., please contact your local distributor.

Please fill in the following information for your reference:

Date of purchase: \_\_\_\_\_

Purchased from: \_\_\_\_\_

## SERVICE:

The following information is provided in the unlikely event that your unit requires service.

1. Be sure that the unit is the cause of the problem. Check to make sure that the unit has power supplied, that all cables are connected correctly, and that the cables themselves are in working condition. You may want to consult with your dealer for assistance in troubleshooting or testing your particular configuration.
2. If you believe that the ART unit is at fault, go to [www.artproaudio.com](http://www.artproaudio.com). Select "Support", then "Return Authorization Request" to request a return authorization number.
3. If you are returning the unit for service, pack the unit in its original carton or a reasonable substitute. The original packaging may not be suitable as a shipping carton, so consider putting the packaged unit in another box for shipping. Print the RA number clearly on the outside of the shipping box. Print your return shipping address on the outside of the box.
4. Include with your unit: a note with the RA number and your contact information, including a return shipping address (we cannot ship to a P.O. box) and a daytime phone number, and a description of the problem, preferably attached to the top of the unit. Also include a copy of your purchase receipt.



**[www.artproaudio.com](http://www.artproaudio.com)**

**E-mail: [support@artproaudio.com](mailto:support@artproaudio.com)**

**© 2026 Applied Research & Technology**

**CLEANBoxPro**

**CBP-5004-101**

**V1.5**