

# dADB

## Dual Active Direct Box

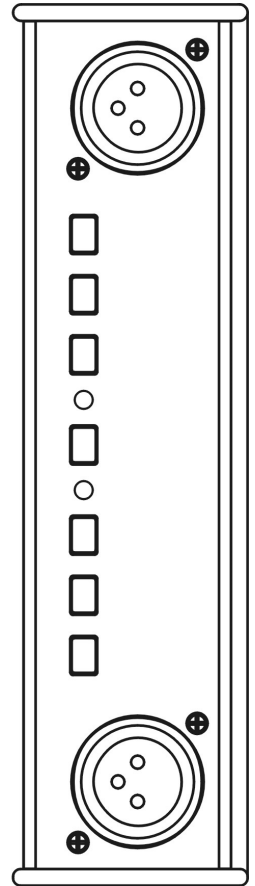

## USER'S MANUAL

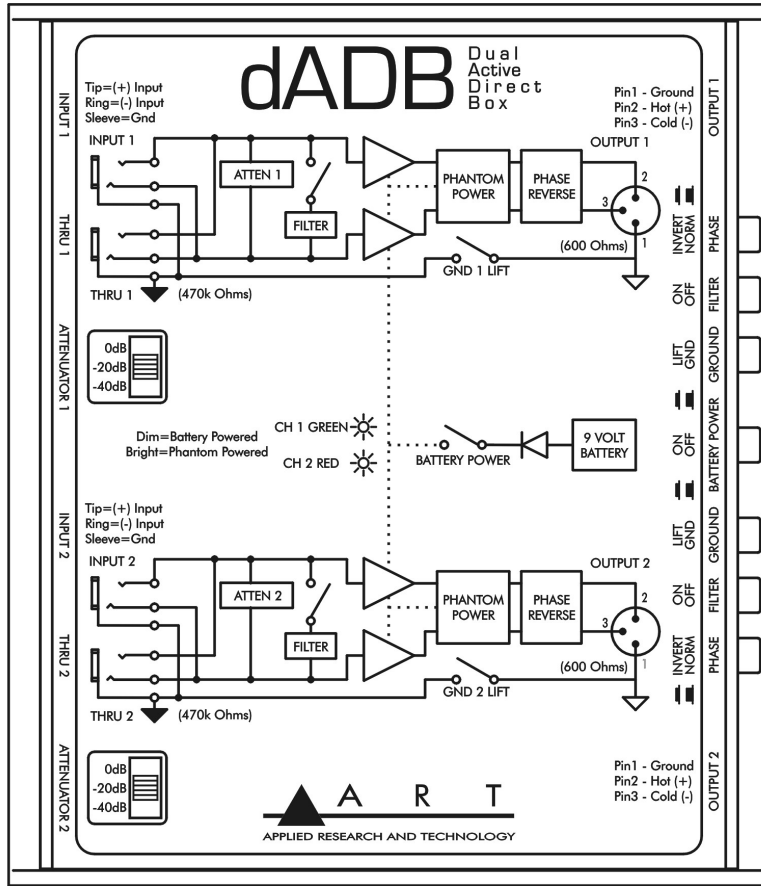
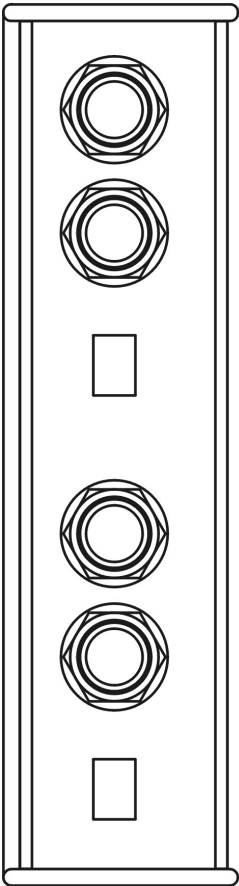

# IMPORTANT SAFETY INSTRUCTIONS - READ FIRST



This symbol, wherever it appears, alerts you to the presence of uninsulated dangerous voltages inside the enclosure that may be sufficient to constitute a risk of shock.



This symbol, wherever it appears, alerts you to important operating and maintenance instructions in the accompanying literature. Please read the manual.

## Read instructions

Retain these safety and operating instructions for future reference. Heed all warnings printed here and on the equipment. Follow the operating instructions printed in this user guide.

## Grounding

Do not defeat the grounding and polarization means of the power cord plug. Do not remove or tamper with the ground connection on the power cord.

## Moisture

To reduce the risk of fire or electrical shock, do not expose the unit to rain, moisture or use in damp or wet conditions. Do not place container of liquid on it, which may spill into any openings

## Heat

Do not locate the unit in a place close to excessive heat or direct sunlight, as this could be a fire hazard. Locate the unit away from any equipment, which produces heat such as: power supplies, power amplifiers and heaters.

## Environment

Protect from excessive dirt, dust, heat, and vibration when operating and storing. Avoid tobacco ash, drink spillage and smoke especially that associated with smoke machines.

## Handling

Protect the controls from damage during transit. Use adequate padding if you need to ship the unit. To avoid injury to yourself or damage to the equipment take care when lifting, moving or carrying the unit.

## Servicing

Switch off the equipment and unplug the power cord immediately if it is exposed to moisture, spilled liquid or the power cord or plug becomes damaged during a lightning storm or if smoke odor or noise is noted. Refer servicing to qualified technical personnel only.

## Installation

Install the unit in accordance with the instruction printed in the user guide.

## OVERVIEW

The ART dADB provides two independent high quality active interfaces that let you connect instrument, line, or speaker level signals to a mixer or other balanced inputs. Each of the high impedance ¼-inch inputs are buffered and converted by very low noise active electronics into an isolated, balanced, low impedance signal output. The dADB has an extremely flat and wide frequency response and can handle high signal levels. This gives the dADB a very clean and neutral sound with a wide variety of signal sources and over long signal runs in high noise environments.

The input ATTENUATOR switches allow for a wide range of signal levels and the input THRU jacks allow for tapping off of your signal chain. The GROUND LIFT switches let you totally separate the input and output signal grounds, when appropriate, to isolate two systems, thereby reducing hum and ground-loop noise.

What further sets the dADB apart from other “DI” boxes are its extended features and versatility. We have added switchable low pass FILTERs that cut out all very high frequency interference. These Bessel filters operate outside of the audio range and are primarily intended to reduce radio frequency interference before it gets into the main system. The filters are also very effective in reducing any digital computer noise artifacts when using the dADB as an interface between a computer-based audio workstation and your monitors. The PHASE INVERT switches allow you to switch signal polarity right at the source. This feature is especially handy when you are combining a direct tap with a microphone feed in the mix.

The dADB's active circuitry is powered by phantom voltage coming into the OUTPUT connections or by an internal 9V battery if external power is not available. When powered by a battery it draws less than 7.5 mA, which should provide more than 100 hours of operation with a new battery (an alkaline battery is recommended). If phantom power is available, then the dADB will automatically draw power from the external source. In this case, if the BATTERY POWER switch is pushed in, a small amount of power will also be drawn from the battery. So be sure the switch is off if you want to run from just phantom power. The POWER LEDs light more dimly when the unit is running from the battery, light more brightly when it is running from phantom power, and are off when the unit is inactive.

The compact black all steel case and it's active design allow the dADB to provide years of trouble free service in Live Sound, Permanent/Fixed Install, D.J., and virtually any PA application. It's full feature set, rugged construction, and high-end specifications make the dADB the obvious choice.

### Features

- Fully active design
- Phantom voltage or 9V battery powered
- Converts high-impedance balanced / unbalanced inputs into 600 Ohm balanced outputs
- Switchable input attenuation (0, -20, -40 dB)
- Switchable low pass filter
- Switchable phase invert
- Switchable ground lift
- ¼-inch TRS connector inputs and thru connections
- XLR connectors for balanced outputs
- Rugged steel case

## INSTALLATION and OPERATION

1. Connect your instrument, line, or speaker level signal to either INPUT ¼-inch TRS jack. If connecting the dADB inline in the signal path, connect one end of a phone plug cable to the corresponding THRU ¼-inch TRS jack and the other end to where your signal was originally going. Repeat for the other INPUT and THRU jacks if desired.
2. Connect a balanced line cable between the corresponding OUTPUT male XLR connector on the rear panel and the balanced inputs of your audio gear. Repeat for the other OUTPUT if desired.
3. If phantom power is not available, make sure a 9V battery is installed\* and push the BATTERY POWER switch in to enable battery power. Both the green and red LEDs will light. When using a battery for power, be sure to turn the switch off when not using the unit to maximize battery life.
4. If phantom power is available, there is no need to push the BATTERY POWER switch in. Phantom power coming into an OUTPUT connector is always applied to the circuit, regardless of the switch setting. The green LED lights brightly when power is coming into the OUTPUT 1 connector and the red LED lights brightly if power is coming into the OUTPUT 2 connector. Both LEDs light if power is coming into both connectors.
5. Note that battery power is connected to both sections of the dADB, whereas phantom power coming into an OUTPUT connector powers only that section. Therefore, you may have a situation where one section is phantom powered and the other is battery powered. In this case, the BATTERY POWER switch would need to be pushed in and the LED of the phantom powered section would be brightly lit and the LED of the battery-powered section would be more dimly lit.
6. Set the input ATTENUATOR switches for best signal strength and clarity. If connecting to speakers, select the -40 dB setting initially and work up, so as not to overdrive the input circuitry. Select the GROUND LIFT feature to lower hum and other ground loop noise, if present. Turn on the FILTERs to remove potential radio frequency (RF) or ultrasonic interference. Use the PHASE INVERT function if necessary.

\* The dADB comes with a 9V battery inside the unit. Before initial use, remove the battery following the access instructions below, remove the outer wrap and reinstall for battery operation.

### Application Example

As an example, suppose a guitarist wants to record a practice session. They would plug their electric guitar into an INPUT jack on the dADB and then plug a cable from the corresponding THRU jack to their guitar amplifier. Their buffered guitar signal could then be sent to a mixing console or recording device from the associated OUTPUT of the dADB.

### Battery Access

To access the battery, remove the four bottom feet from the unit using a Phillips screwdriver and separate the two parts of the enclosure. Remove the old battery (if installed) from the cardboard sleeve and disconnect the battery clip. Connect the battery clip to the new battery and reinsert the battery into the sleeve. Reassemble the unit.

If the unit is going to be powered exclusively from phantom power, or if the unit is not going to be used for a long period of time, we recommend removing the battery to prevent possible corrosion due to battery leakage.

## WARRANTY INFORMATION

### Limited Warranty (USA only)

Applied Research and Technology will provide warranty and service for this unit in accordance with the following warrants:

Applied Research and Technology, (A R T) warrants to the original purchaser that this product and the components thereof will be free from defects in workmanship and materials for a period of **three** years from the date of purchase. Applied Research and Technology will, without charge, repair or replace, at its option, defective product or component parts upon prepaid delivery to the factory service department or authorized service center, accompanied by proof of purchase date in the form of a valid sales receipt.

### Online Registration

We recommend that you register your product online to insure prompt warranty repair servicing on any repair issues. Please go to [www.artproaudio.com](http://www.artproaudio.com). Select "*Support*", then "*Product Registration*" input your information here.

### Exclusions

This warranty does not apply in the event of misuse or abuse of the product or as a result of unauthorized alterations or repairs. This warranty is void if the serial number is altered, defaced, or removed.

A R T reserves the right to make changes in design or make additions to or improvements upon this product without any obligation to install the same on products previously manufactured.

A R T shall not be liable for any consequential damages, including without limitation damages resulting from loss of use. Some states do not allow limitations of incidental or consequential damages, so the above limitation or exclusion may not apply to you. This warranty gives you specific rights and you may have other rights, which vary from state to state.

For units purchased outside the United States, an authorized distributor of Applied Research and Technology will provide service.

## SERVICE

The following information is provided in the unlikely event that your unit requires service.

1. Be sure that the unit is the cause of the problem. Check to make sure the unit has power, all cables are connected correctly, and the cables themselves are in working condition. You may want to consult with your dealer for assistance in troubleshooting or testing your particular configuration.
2. If you believe that the ART unit is at fault, go to [www.artproaudio.com](http://www.artproaudio.com).
3. Select "*Support*", then "*Return Authorization Request*" to request a return authorization number.
4. If you are returning the unit for service, pack the unit in its original carton or a reasonable substitute. The original packaging may not be suitable as a shipping carton, so consider putting the packaged unit in another box for shipping. Print the RA number clearly on the outside of the shipping box. Print your return shipping address on the outside of the box.
5. Include, with your unit, a note with the RA number and your contact information, including a return shipping address (we cannot ship to a P.O. box) and a daytime phone number, and a description of the problem, preferably attached to the top of the unit. Also include a copy of your purchase receipt.

**Please fill in the following information for your reference:**

Date of purchase: \_\_\_\_\_

Purchased from: \_\_\_\_\_

Serial Number: \_\_\_\_\_

## SPECIFICATIONS

Frequency Response	10 Hz - 100 kHz, $\pm 0.5$ dB @ +0 dBu
THD	<.05% (typical)
Dynamic Range	>100 dB (typical)
Channel Separation	> 80 dB (typical)
Maximum Input Level	+4, +24, +44 dBu (depending on attenuator setting)
Maximum Output Level	+6 dBu (battery powered), +14 dBu (phantom powered)
Input Connections	¼-inch TRS balanced / unbalanced (2), 470k Ohm
Thru Connections	¼-inch TRS (2)
Output Connections	XLR male balanced (2), <600 Ohm
Input Attenuation	Switchable (0, -20, -40 dB)
Power Requirements	9V @ 7.5 mA (battery, alkaline recommended), 18 - 48V DC @ 6.4 mA (phantom power, per channel)
Dimensions (HWD)	2-inch x 5-inch x 5.75-inch 51mm x 127mm x 146mm
Weight	2.7 lbs / 1.22 kg



**[www.artproaudio.com](http://www.artproaudio.com)**  
**E-mail: [support@artproaudio.com](mailto:support@artproaudio.com)**

© 2019 Applied Research & Technology

**dADB V1.2**  
**Dual Active Direct Box**