

PS8 - II

POWER SEQUENCER



USER'S MANUAL



IMPORTANT SAFETY INSTRUCTIONS – READ FIRST



This symbol, wherever it appears, alerts you to the presence of uninsulated dangerous voltage inside the enclosure. Voltage that may be sufficient to constitute a risk of shock.



This symbol, wherever it appears, alerts you to important operating and maintenance instructions in the accompanying literature. Please read manual.

Read instructions:

Retain these safety and operating instructions for future reference. Heed all warnings printed here and on the equipment. Follow the operating instructions printed in this user guide.

Do not open:

Aside from two vacuum tubes, there are no user serviceable parts inside. Refer any service work to qualified technical personnel only.

Power sources:

Only connect the unit to mains power of the type marked on the rear panel. The power source must provide a good ground connection.

Power cord:

Use the power cord with sealed mains plug appropriate for your local mains supply as provided with the equipment. If the provided plug does not fit into your outlet consult your service agent. Route the power cord so that it is not likely to be walked on, stretched or pinched by items placed upon or against.

Grounding:

Do not defeat the grounding and polarization means of the power cord plug. Do not remove or tamper with the ground connection on the power cord.

Ventilation:

Do not obstruct the ventilation slots or position the unit where the air required for ventilation is impeded. If the unit is to be operated in a rack, case or other furniture, ensure that it is constructed to allow adequate ventilation.

Moisture:

To reduce the risk of fire or electrical shock do not expose the unit to rain, moisture or use in damp or wet conditions. Do not place a container of liquid on it, which may spill into any openings.

Heat:

Do not locate the unit in a place close to excessive heat or direct sunlight, as this could be a fire hazard. Locate the unit away from any equipment, which produces heat such as: power supplies, power amplifiers and heaters.

Environment:

Protect from excessive dirt, dust, heat, and vibration when operating and storing. Avoid tobacco ash, drink spillage and smoke, especially that associated with smoke machines.

Handling:

To prevent damage to the controls and cosmetics avoid rough handling and excessive vibration. Protect the controls from damage during transit. Use adequate padding if you need to ship the unit. To avoid injury to yourself or damage to the equipment take care when lifting, moving or carrying the unit.

Servicing:

Switch off the equipment and unplug the power cord immediately if it is exposed to moisture, spilled liquid, objects fallen into opening, or the power cord or plug becomes damaged during a lightning storm or if smoke odor or noise is noted. Refer servicing to qualified technical personnel only.

Installation:

Install the unit in accordance with the instructions printed in the user manual.

INTRODUCTION

The PS8-II provides controlled power sequencing to 8 rear AC outlets. Each output is delayed by a fixed amount that is determined by the front panel Sequence Delay control. This allows you to control the power up and down sequence in a system to minimize turn-on transients and the damage that they may cause. Sequencing power on also smooths out inrush currents. Remote switching is also provided for via a rear mounted Remote connector, handy when you want to keep noisy or hot equipment in one room and control power remotely.

The PS8-II is also a full-featured power conditioner, with fast acting breaker, EMI and RFI filtering, as well as surge and spike protection to protect your system. The PS8-II is designed to sequence and protect a wide range of equipment from sensitive tube preamps to powered speakers, large displays, or digital systems. Your equipment will sound and work better and live longer.

FEATURES

- Adjustable sequence delay range from 0.5 to 2.0 seconds per output step
- 8 individually sequenced outputs with front panel LED indicators for each
- Rear mount remote control terminal block for remote sequence control
- Front panel unswitched and unregulated output
- 1800 Watt total power capacity
- Front panel master breaker and power switch
- EMI and RFI filtering
- Surge and Spike Protection

OPERATION

POWER SWITCH

The **PS8-II** has a master POWER switch for the rear outlets. This switch glows when the unit is enabled. If the rear REMOTE is not being used, turning on this switch initiates a power on sequence for the rear outlets. Turning off the switch initiates a power off sequence and the rear outlets are then sequenced off.

NOTE: The front panel Main POWER switch must remain in the ON position in order for the remote switching to function.

CH1-CH8 LED INDICATORS

The CH1-CH8 LED indicators, on the front panel, indicate the current power (on/off) status. If power is available at a rear outlet then it's corresponding front panel indicator will be lit.

SEQUENCE DELAY

The front panel sequence delay control allows you to set the delay time between activation of each outlet. Its range is from 0.5 to 2.0 seconds. If set to 2.0 seconds, for example, there will be a 2 second delay between each outlet turning on or off in the sequence (16 seconds total delay from initial power on to CH8 power on). This gives you a wide range of control when setting the application of power to your system, thereby minimizing any unwanted effects.

REMOTE SWITCHING

The rear panel REMOTE connection block allows for external control of the power on and off sequence. If there are no connections to this block then the **PS8-II** functions normally with all sequencing initiated by the front panel power switch. Connecting the REMOTE and GROUND terminals together at this block initiates a power off sequence and all rear outlets are held in the OFF position. Once this connection is removed the **PS8-II** will sequence the rear outlets back on as long as the front panel power switch on. This allows you to run a simple 2-wire low voltage (+5Volt) connection to a remote switch or relay to remotely control the system. Useful for fixed install, conferencing, multi-media systems, recording studio/control rooms, and central control of equipment on stage in a live venue. A status indicator terminal, with internal 1K-Ohm resistor connected to +5Volts, allows for direct powering of a remote indicator LED (if required). A +5 Volt terminal is also provided to power an external relay or other control circuitry (if required). The following diagrams give just 2 examples of how you would connect.

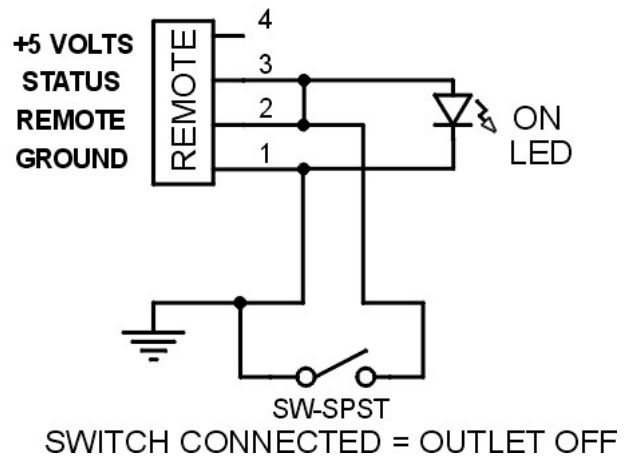
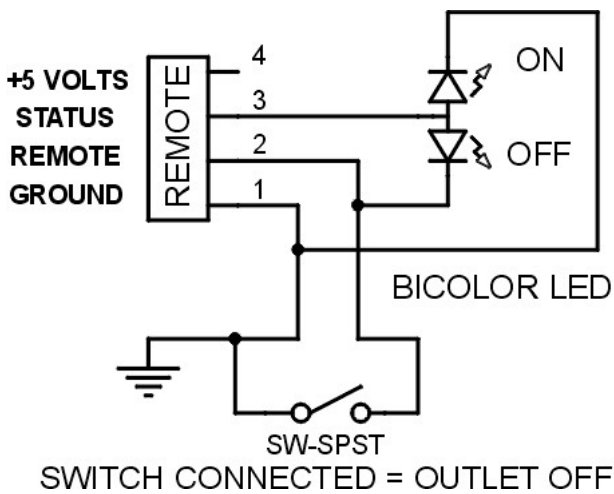

MAXIMUM LOAD

The eight circuit breaker protected outlets are rated at 15 amps total, which is equivalent to 1800 watts at 120 volts. If the total load on the **PS8-II** exceeds 15 amps, the circuit breaker on the front panel will trip, cutting off power to all outlets. If this happens, reduce the overall load by unplugging one or more units from the **PS8-II**, then push the circuit breaker button in to reset it. Each outlet should be limited to a maximum of 10 amps, this will ensure the long term durability of the relays.

POWER FILTERING

The **PS8-II** has specialized internal circuitry to filter out digital and dimmer hash as well as any high frequency noise that is above the audio range.

By using both Common Mode and Differential Mode topologies in series for the filter design we are able to block virtually all of the unwanted noise that is between the AC line and ground, and also the two sides of the AC line. This has the additional benefit of reducing ground loop problems in your system.

High frequency noise currents in particular are highly attenuated in both directions so that any line noise that could be generated by one of your components is not allowed to get back into your main AC wiring, so if you use a **PS8-II** in your setup, you can distribute and isolate the noisy components from the sensitive components in your system. Additionally, any signals above 10kHz are filtered from the line with typically 40dB of attenuation above 100kHz.

WARRANTY INFORMATION

Limited Warranty

Applied Research and Technology will provide warranty and service for this unit in accordance with the following warrants:

Applied Research and Technology (A R T) warrants to the original purchaser that this product and the components thereof will be free from defects in workmanship and materials for a period of **three** years from the date of purchase. Applied Research and Technology will, without charge, repair or replace, at its option, defective product or component parts upon prepaid delivery to the factory service department or authorized service center, accompanied by proof of purchase date in the form of a valid sales receipt.

Exclusions

This warranty does not apply in the event of misuse or abuse of the product or as a result of unauthorized alterations or repairs. This warranty is void if the serial number is altered, defaced, or removed.

A R T reserves the right to make changes in design or make additions to or improvements upon this product without any obligation to install the same on products previously manufactured.

A R T shall not be liable for any consequential damages, including without limitation damages resulting from loss of use. Some states do not allow limitations of incidental or consequential damages, so the above limitation or exclusion may not apply to you. This warranty gives you specific rights and you may have other rights, which vary, from state to state.

For units purchased outside the United States, an authorized distributor of Applied Research and Technology will provide service.

SERVICE

The following information is provided in the unlikely event that your unit requires service.

1. Be sure that the unit is the cause of the problem. Check to make sure the unit has power, all cables are connected correctly, and the cables themselves are in working condition. You may want to consult with your dealer for assistance in troubleshooting or testing your particular configuration.
2. If you believe that the ART unit is at fault, go to **www.artproaudio.com**.
3. Select “*Support*”, then “*Return Authorization Request*” to request a return authorization number.
4. If you are returning the unit for service, pack the unit in its original carton or a reasonable substitute. The original packaging may not be suitable as a shipping carton, so consider putting the packaged unit in another box for shipping. Print the RA number clearly on the outside of the shipping box. Print your return shipping address on the outside of the box.
5. Include, with your unit, a note with the RA number and your contact information, including a return shipping address (we cannot ship to a P.O. box) and a daytime phone number, and a description of the problem, preferably attached to the top of the unit. Also include a copy of your purchase receipt.

Fill in the following information for your reference:

Date of purchase _____

Purchased from _____

Serial Number _____

PS8-II SPECIFICATIONS

Power capacity	1800watts
Maximum load	15 amps (1800 watts @ 120 VAC)
Outlets	8 rear individually sequenced outlets, 1 front unswitched
Delay time	0.5 to 2.0 sec Variable pot
Remote switch	on/off function
Remote terminal	Rear mounted 4pin Euro connector
Line filtering	RFI / EMI
Power Requirements	USA – 105 to 125 VAC / 60 Hz Export units configured for country of destination.
Dimensions (HWD)	1.75-inch x 19.0-inch x 11.5-inch 165mm x 482mm x 292mm
Weight	9.2 lbs. (4.2kg)



www.artproaudio.com

E-mail: support@artproaudio.com

© 2016 Applied Research & Technology